



PUBLIC WORKS

2023 Parts Catalog



DICKY-john[®]
A DIVISION OF TSI[®]



TABLE OF CONTENTS

CONTROL SYSTEMS

CONTROL POINT®

- 1 System Features
- 2 Data Retrieval (Wireless Transfer)
- 3 Console and Accessories
- 4 Road Temperature Adapters
- 5 Sensor and Switches
- 6 System Wiring Diagram (Main Harness)
- 8 System Wiring Diagram (Switch Module Harness)
- 9 CP Combo Parts Order List
- 11 CP Combo Liquid Parts Order List

HYDRAULIC VALVES

DUAL FLOW AND PROPORTIONAL FLOW

- 13 Specifications and Part Numbers

SINGLE FLOW (HYDRAULIC SERVO)

- 14 Specifications and Part Numbers

FLOW METERS

- 15 Pre-Wet Flow Meters
- 16 Poly Sensor Service Parts and Raven Adapter

SENSORS

AUGER/CONVEYOR

- 17 Application Rate Sensor, Harness, Hardware, and Tester
- 18 Application Rate Sensor Accessories

GROUND SPEED

- 19 Radar II, Radar III, and Hall-Effect
- 20 Speedometers and Adapters
- 22 Hopper Level and Liquid Pressure Sensor

VALVE DRIVERS

- 23 SMD, Hydraulic, and Linear
- 24 PWM, Electric Pump, and Liquid Servo
- 25 Linear and Adapter Cable

LIQUID CONTROL VALVES

- 26 Two-Way Stainless Steel, Poly, and Carbon Steel
- 27 Three-Way and Raven Fast Valve Adapter Harness
- 28 Liquid Boom Shutoff, Actuators, Valve Fittings
- 29 Liquid Valve Bodies
- 30 Actuator Assemblies

HARNESSES

- 31 Sensor, Ground Speed, and Valve Extensions

SIMULATORS

- 32 Universal Proportional, Flex4™, and Ground Speed

MANUALS

- 33 Operator's Manuals and Sales Literature

TABLE OF CONTENTS

SERVICE PARTS

35	Flex4™ System Wiring Diagram
40	Flex4 Pro™
51	LT Spreader Control
52	ICS2000
56	Control Point®
57	Joystick
59	PVC3000
61	Ground Speed Control
61	Accessories
62	Hydraulic Servo - Single Flow
63	ICS2000 Console Parts
64	Connectors & Kits

Control Point®

Features



Control Point® is a closed-loop control system used for controlling granular and liquid material application rates, spinner speed, and spread width. The system is designed to work with a variety of actuators including drop-on actuators (servo valves), pulse-width modulated valves, electric pumps, and motorized ball valves.

The latest Control Point® software release 7.0 offers users enhanced capabilities:

- Pause function
- Wireless communication between computer and truck fleet
- Granular rate adjustment based on liquid rate application

Software version 7.0 is compatible with all Control Point previous software versions (excluding 466491671 and greater)

The Control Point system basic components include:

1. Console
2. Standard Switch Module or Wireless Switch Module
3. Ground Speed Sensor
4. Feedback devices to monitor application rates
5. Actuator devices to regulate application rates
6. Harnesses to interconnect all system devices
7. Base Station (wireless communication only)

The detachable keyboard and PC tool software are considered programming and reporting aids that are not part of the basic Control Point system.

Features:

- Detachable keyboard for simplistic programming
- Liquid flow
- One digital accessory with programmable label
- One analog accessory (pressure or tank level)
- Standard RS232 port for GPS or printer

Determining System Components

To order a Control Point system, the following information is required to ensure the proper system is selected for the correct application.

1. Transmission Type
 - What speed sensor adapter is required?
2. Valve Type
 - What valve will control conveyer, auger, spinner hydraulics?
4. Application Rate Sensor
 - Which application rate sensor and adapter is required?
5. Cable length
 - What is the correct cable length for the application rate sensor?
6. Liquid Components
 - What liquid components are required for pre-wet/anti-ice application?

Any Control Point systems ordered require a calibration keyboard for entry of calibration and programming data. One keyboard can be shared among multiple trucks.

Control Point®

Data Retrieval (Wireless Transfer)

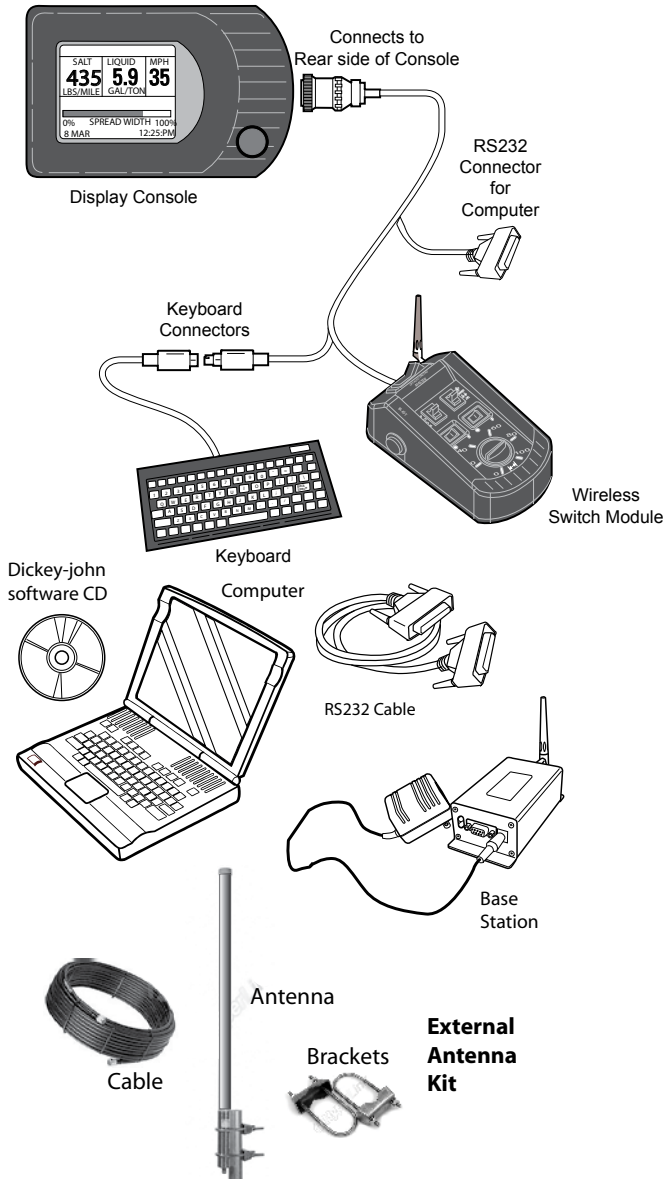

Wireless transmission of truck fleet data to a computer eliminates the direct connection of computer to Control Point®. Wireless download occurs when trucks are stationary and within 400' from the base station and the CP Tools software looping function is activated on the computer.

The following components are required for wireless compatibility:

- Control Point® Software version 7.28 or higher and hardware version 3
- CP Tools Software (computer)
- Wireless Switch Module (truck)
- Wireless Base Station (computer)
- External antenna for clear reception (recommended option with Wireless Base Station)

The CP Tools software required for wireless communication is also an effective tool for non-wireless users.

CP Tools software enhancements provide:

- Uploading of Control Point software upgrades
- A convenient computer reporting tool with user-friendly interface screen that packages previous software reporting functions.

CP Tools software is compatible with Windows 2000 or XP operating systems.

Optional:

An external antenna kit is recommended for wireless applications and provides reliable reception when a signal is compromised between trucks and base station, i.e. brick buildings, no windows. Antenna provides a line of sight horizontal signal with a straight 400' effective diameter and includes a 100' cable for optimal location.

Fleet Summary Report Example

Region: NM		Truck ID: 110011391		Date: 7-Nov-2006	
CURRENT					
35.7 MILES		Auto	Pause	Blast	0.00 HR
0.0 MILES					0.0 MILES
Material	TONS	MILES	Time	TONS	MILES
1 SALT	0.0	0.0	0.00	0.0	0.0
2 SAND	10.6	35.4	1.04	0.0	0.0
Auto					
Material	GAL	MILES	Time	GAL	MILES
1 PREHEAT	53.1	35.4	1.04	0.0	0.0
2 DRICING	0.0	0.0	0.00	0.0	0.0
SEASON					
1423.2 MILES		Auto	Pause	Blast	0.00 HR
0.0 MILES					0.0 MILES
Material	TONS	MILES	Time	TONS	MILES
1 SALT	0.0	0.0	0.00	0.0	0.0
2 SAND	10.6	35.4	1.04	0.0	0.0
Auto					
Material	GAL	MILES	Time	GAL	MILES
1 PREHEAT	53.1	35.4	1.04	0.0	0.0
2 DRICING	0.0	0.0	0.00	0.0	0.0

Part Number	Description
466493200S1	Wireless Switch Module
466493400S1	Wireless Base Station
EXT ANT KIT	External Antenna Kit (100' external antenna cable, external antenna, mounting hardware)
466493400S2	Base Station with CP Tools Software
466493500S1	100' External Antenna Cable
466493600S1	External Antenna with Mounting Hardware
466493150S1	CP Wireless PC Tools Software CD

Control Point®

Console and Accessories

Console



Console

A three-channel control system simultaneously controls the spreading of granular and liquid ice-control materials. Two channels control granular and liquid application rates and the third channel precisely controls spinner speed to maintain even material coverage over the desired spread width.

Part Number	Description
466491670S1	Console

Switch Module



Standard Switch Module

Wireless Switch Module

Real-time functions of the Control Point® are controlled by the switch module (master off/auto/unload, channel on/off, channel APR inc/dec, blast, spread width adjust)

The Wireless Switch Module allows data transfer to a PC via a wireless transmission to a base station.

Part Number	Description
466493300S1	Standard Switch Module
466493200S1	Wireless Switch Module

Keyboard



Keyboard

Keyboard is required to program and calibrate the system.

Part Number	Description
466490850S1	Calibration Keyboard (English)

Wireless Base Station



Wireless Base Station

Wireless base station is required to communicate with the wireless switch module for data transfer to a PC.

Part Number	Description
466493400S1	Base Station

Harnesses



Harness

Part Number	Description
466490485S1	Main Harness (new style)
466490487S1	ICS to Control Point® Adapter Harness (new style)

Miscellaneous

Part Number	Description
466490381S1	Console/Switch Module Mounting Hardware
466490391S1	Console Mounting Hardware
466491440	Dust Cap Kit
210190020	Dust Cap for RS-232 (included in 466491440)
210190021	Dust Cap for Keyboard (included in 466491440)

Need more harness length in the cab?

The crew cab harness is six feet longer from the main connector to the first breakout. All other functionality is the same between the main harness and the crew cab main harness. Refer to pages 6-8 for wire schematics.

Control Point®

Road Temperature

RoadWatch



Adapter connects the RoadWatch sensor to the Flex4 Pro™ or Control Point®. Version 6.3 or newer software is required to display and record road and air temperature.

Part Number	Description
466494100S1	RoadWatch® Truck Adapter with EDAC connector

RoadWatch Sensor

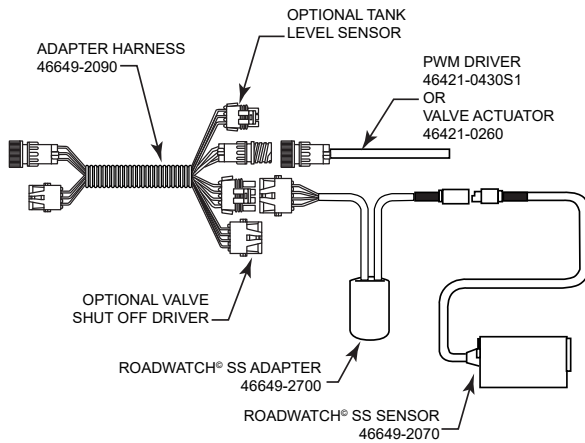

Surface Patrol Adapter Harness

Surface Patrol Adapter Harness

Adapter connects the Surface Patrol spreader interface to the Flex4 Pro™ or Control Point®. Version 6.3 or newer software is required to display and record road and air temperature.

Part Number	Description
466492100S1	Surface Patrol Adapter Harness

Control Point®

Sensors and Switches



Gate Height Sensor

Measures gate height setting in inches and automatically adjusts conveyor speed to compensate for gate height changes and maintain application rate. Software version 6.3 or higher is required to display and control the conveyor speed to the gate height.

Part Number	Description
466492370S1	Gate Height Sensor



Pre-Wet/Anti-Ice Switch

Pre-Wet/Anti-Ice Switch

Automatically signals the Control Point® to change from pre-wet to anti-ice. Allows integration of two flow meters and two valve drivers.

Part Number	Description
46649-1690S1	Pre-Wet/Anti-Ice Switch



Down Pressure Sensor

Down Pressure Sensor

Hydraulic pressure sensors measure the amount of down pressure applied on the underbody scraper. Software version 6.4 or higher is required to display and alarm down pressure.

Part Number	Description
465700080S1	Down Pressure Sensor



Flow Meter Sensor

Flow Meter Sensor

Flow meter measures the flow rate of material applied. Used with pre-wet systems.

Part Number	Description
466491170S1	Pre-Wet Flow Meter Sensor (0.2 - 5 gpm)

Control Point®

System Wiring Diagram

Main Harness (46649-0485S1)

Note: Alpha characters in front of pin numbers indicate pin numbers of console connector.

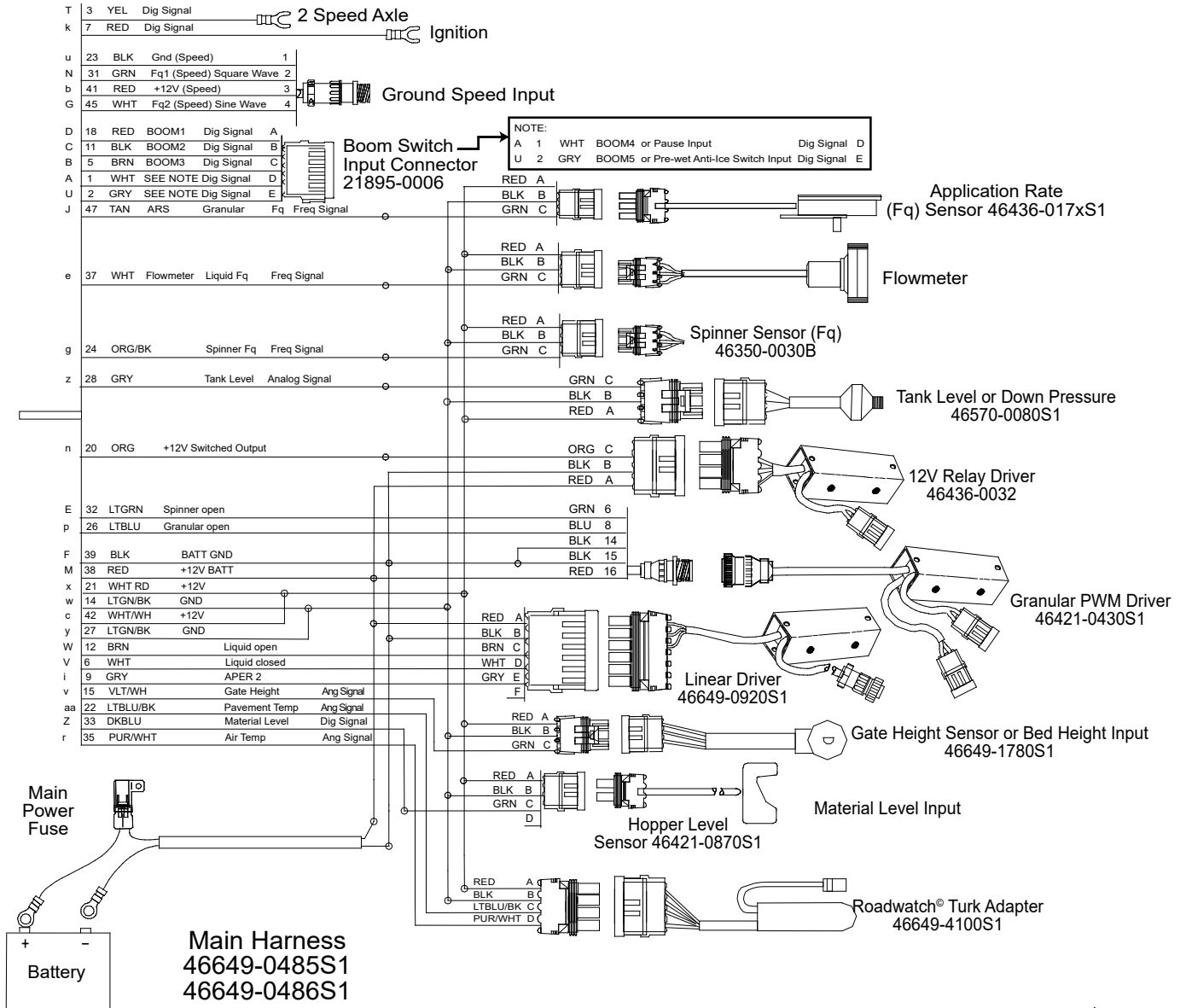

Control Point®

System Wiring Diagram

Main Harness (46649-0480S1) replaced by 46649-0485S1

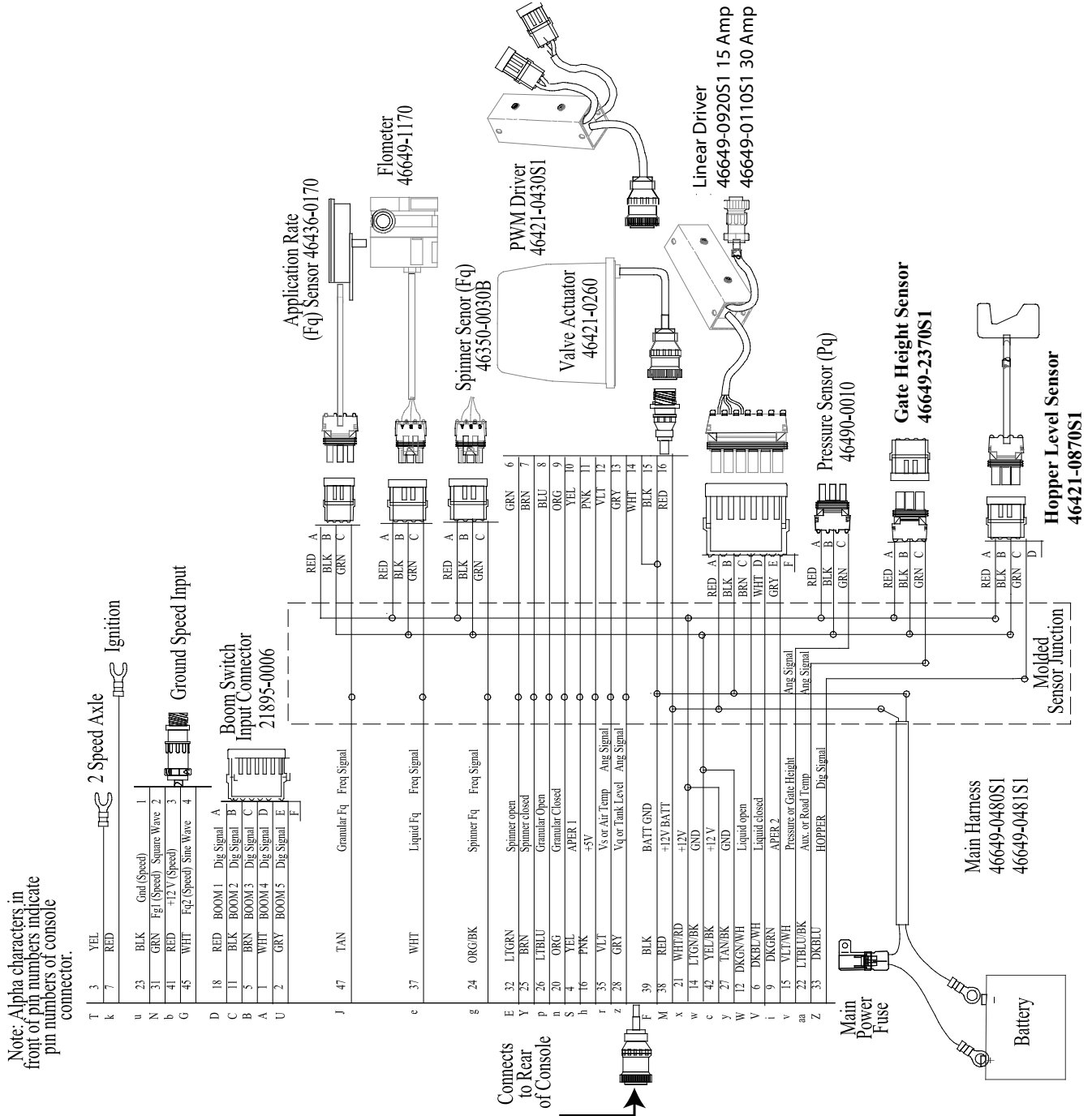

Control Point®

System Wiring Diagram

Switch Module Harness (46649-3300S1)

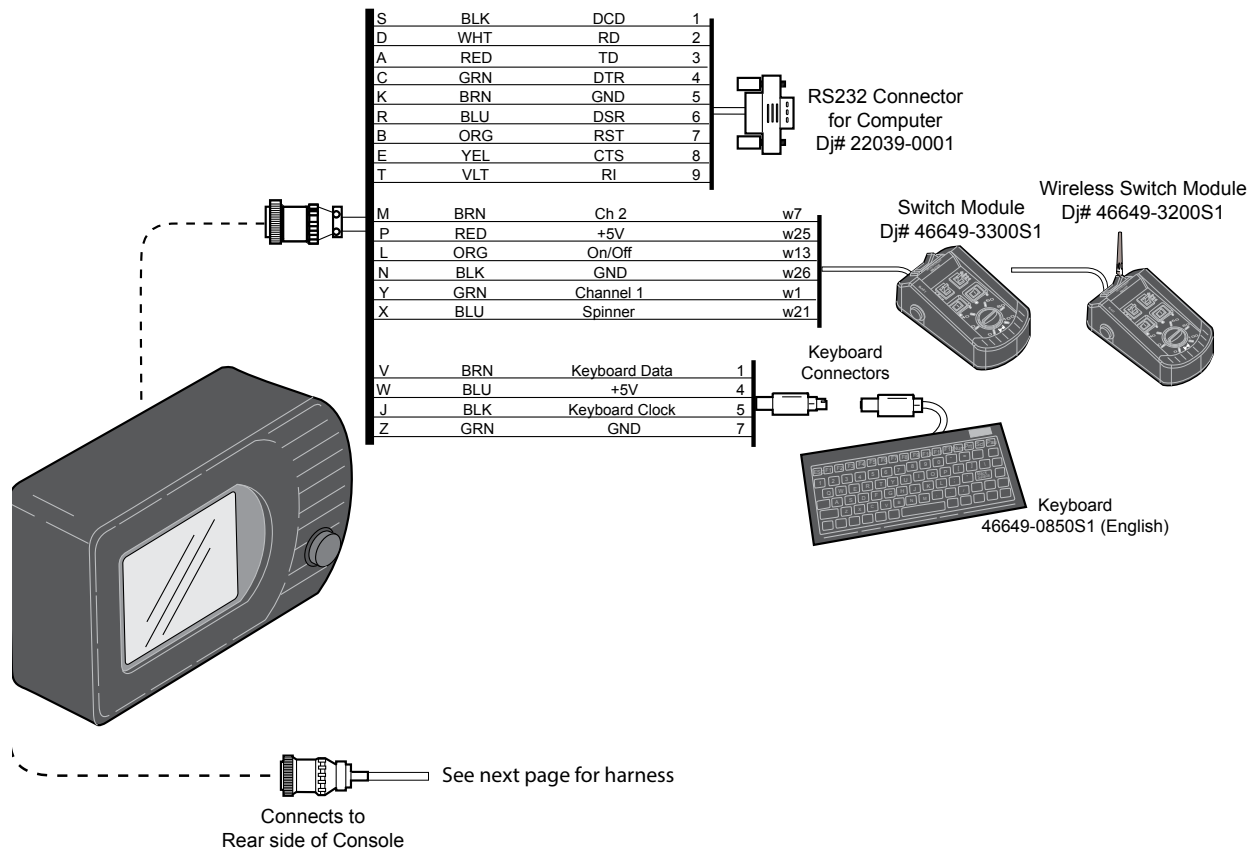

Refer to page 56 for Console parts, Switch Module parts,
and Console Mounting Hardware parts.

Control Point®

CP Combo Parts Order List

To order a Control Point® system, the following information is required to ensure the proper system is selected for the correct application. Any Control Point® systems ordered require a calibration keyboard for entry of calibration and programming data. One keyboard, p/n 466490850S1, can be shared among multiple trucks.

Selecting System Components

CONTROL POINT SYSTEM			
PART NUMBER	DESCRIPTION		
CPCOMBO 466490485S1 464210430S1 466491440 110011489	Control Point System Base Kit 6.3SW and newer Control Point Reg Cab Main Harness A/S PWM Valve Driver Dust Cap Kit Operator's Manual	Control Point Consoles ordered must match number of Control Point System Base Kits ordered.	
	CONTROL POINT CONSOLE		
	CPBASICCSLE	Control Point Console	Console required with each system.
	ACCESSORIES		
CONSOLE MOUNTING HARDWARE (select 1)			
466490381S1	Hardware Kit Console/Switch Module		
466390910S1	Hardware Kit Switch Module Mount Only		
OPERATOR SWITCH MODULE (select 1)			
466493200S1	Control Point Switch Module w/Wireless Com Port	CP software version 7.0 required.	
466493300S1	Control Point Switch Module		
SPEED SENSORS (select 1)			
464210507S1	El Speedo Navistar Sine Wave		
464210508S1	El Speedo Ford Sine Wave		
464210509S1	El Speedo w/Metri Pack Connectors Sine Wave		
464211450	El Speedo Navistar w/Deutsch Connectors Sine Wave	Which speed sensor adapter is required.	
464211440	El Speedo World Trans ECU V20n Socket Conn Sq Wave		
463170192	El Speedo World Trans Wire 157 Sq Wave		
463170191	El Speedo World Trans Wire 157 Sq Wave		
466492130S1	El Speedo Navistar 5000/7000 12 VVW Option		
APPLICATION RATE SENSORS (select 1)			
464360170S1	Application Rate Sensor 10' Cable		
464360171S1	Application Rate Sensor 15' Cable		
464360172S1	Application Rate Sensor 30' Cable		
464360176S1	Application Rate Sensor 5' Cable	Which application rate sensor or adapter is required.	
464360177S1	Application Rate Sensor 22' Cable		
464360178S1	Application Rate Sensor 1' Cable		
ARS/FLOW METER EXTENSION OPTIONS (select 1)			
457901810	Extension Cable 15'		
457901811	Extension Cable 30'	What is the correct cable length required for the flow meter and/or application rate sensor.	
457901812	Extension Cable 45'		
LIQUID DRIVER EXTENSION HARNESES (select 1)			
466490961	Liquid Driver Extension 30'		
466490960	Liquid Driver Extension 20'		
LIQUID VALVE DRIVERS (select 1)			
466490920S1	Liquid Valve Driver 15 Amp	Liquid Valve Drivers are used with electric pumps or PWM hydraulic valves.	
464900010S1	Liquid Valve Driver 30 Amp		
466492530S1	KZ Valve Driver		
ARS MOUNTING HARDWARE (select 1)			
457141810	Hardware GC1000-S 1" Coupler		
457141850	Hardware GC1000-S 1.25" Coupler		
VALVE EXTENSION OPTION (select 1)			
464211180	Dual PWM Valve Extension Harness 15'	Extension option for PWM Valve Driver 464210430S1.	
OPTIONS			
FLOW METERS			
466491170S1	Pre Wet (0.3 - 5 GPM)		
PM00370023S1	3/4" Poly (1.85 - 18.5 GPM)		
PM00370030S1	1" Poly (2.64 - 26.4 GPM)		
PM00370040S1	1.5" Poly (9.25 - 92.5 GPM)		
PM00370048S1	2" Poly (19.0 - 198 GPM)		
PM00370048S2	2" Poly w/1.5" Hose Barbs (19.0 - 198 GPM)		
PM00370068S1	3" Poly (39.6 - 396 GPM)		
466980040S1	Raven Flow Meter Adapter		
TEMPERATURE SENSOR ADAPTERS			
466494100S1	Road Watch SS		
466492100S1	Surface Patrol		

Control Point®

CP Combo Parts Order List

Selecting System Components

CONTROL POINT® SYSTEM	PART NUMBER	DESCRIPTION
	MISCELLANEOUS SENSORS	
	465700080S1	Down Pressure Hydraulic Sensor
	466492370S1	Gate Height Sensor
	VALVES	
	467092004S1	4 GPM Valve
	467092008S1	8 GPM Valve
	467092100	17/10 Hydraulic Valve
	467092101	17/10 Hydraulic Valve Load Sense
	467092110	34/10 Hydraulic Valve
	467092111	34/10 Hydraulic Valve Load Sense
	46709xxxx	PVC3000 Hydraulic Valve CALL FOR QUOTE
	VALVE & ACTUATOR ASSEMBLIES	
	467095010	Valve & Actuator Assembly 3/8" 2 way SS
	467095020	Valve & Actuator Assembly 1/2" 2 way SS
	467095030	Valve & Actuator Assembly 3/4" 2 way Poly
	467095300	Valve & Actuator Assembly 3/4" 2 way SS
	467095040	Valve & Actuator Assembly 1" 2 way CS
	467095280	Valve & Actuator Assembly 1" 2 way Poly
	467095290	Valve & Actuator Assembly 1" 2 way SS
	467095050	Valve & Actuator Assembly 1.5" 3 way Poly
	467095140	Valve & Actuator Assembly 1.5" 3 way SS
	467095150	Valve & Actuator Assembly 2" 2 way SS
	467095160	Valve & Actuator Assembly 2" 3 way SS
	467095170	Valve & Actuator Assembly 3" 2 way SS
	467095320	Valve & Actuator Assembly 1/4" 2 way SS
	LIQUID VALVE EXTENSION CABLES	
	457901820	Liquid Valve Extension Cable 15'
	457901821	Liquid Valve Extension Cable 30'
	KEYBOARD	
	466490850S1	Control Point® Programming Keyboard
	WIRELESS MISCELLANEOUS	
	466493400S1	Wireless Base Station (connects to office PC)
	466493400S2	Wireless Base Station and PC Software Kit
	466493500S1	100' External Antenna Cable
	466493600S1	External Antenna with Mounting Hardware
	EXT ANT KIT	External Antenna and 100' Antenna Cable Kit

Control Point®

CP Combo Liquid Parts Order List

Selecting System Components

CONTROL POINT® SYSTEM	PART NUMBER	DESCRIPTION	
CPLIQUIDSYS Base Kit includes 1 each of parts included in highlighted box.	CPLIQUIDSYS Control Point® System Liquid Base Kit		
	466490485S1	6.3SW and newer Control Point Reg Cab Main Harness A/S	Control Point Consoles ordered must match number of Control Point System Base Kits ordered.
	466491440	Dust Cap Kit	
110011489	Operator's Manual		
	CONTROL POINT CONSOLE		
	CPBASICCSLE	Control Point® Console	Console required with each system.
ACCESSORIES			
	CONSOLE MOUNTING HARDWARE (select 1)		
	466490381S1	Hardware Kit Console/Switch Module	
	466390910S1	Hardware Kit Switch Module Mount Only	
	OPERATOR SWITCH MODULE (select 1)		
	466493200S1	Control Point Switch Module w/Wireless Com Port	CP software version 7.0 required.
	466493300S1	Control Point Switch Module	
	SPEED SENSORS (select 1)		
	464210507S1	El Speedo Navistar Sine Wave	Which speed sensor adapter is required.
	464210508S1	El Speedo Ford Sine Wave	
	464210509S1	El Speedo w/Metri Pack Connectors Sine Wave	
	464211450	El Speedo Navistar w/Deutsch Connectors Sine Wave	
	464211440	El Speedo World Trans ECU V20 Socket Conn Sq Wave	
	463170192	El Speedo World Trans Wire 157 Sq Wave	
	463170191	El Speedo World Trans Wire 157 Sq Wave	
	466492130S1	El Speedo Navistar 5000/7000 12 VVW Option	
	ARS/FLOW METER EXTENSION OPTIONS (select 1)		
	457901810	Extension Cable 15'	What is the correct cable length required for the flow meter and/or application rate sensor.
	457901811	Extension Cable 30'	
	457901812	Extension Cable 45'	
	LIQUID DRIVER EXTENSION HARNESSSES (select 1)		
	466490961	Liquid Driver Extension 30'	
	466490960	Liquid Driver Extension 20'	
	LIQUID VALVE DRIVERS (select 1)		
	466490920S1	Liquid Valve Driver 15 Amp	Liquid Valve Drivers are used with electric pumps or PWM hydraulic valves.
	464900010S1	Liquid Valve Driver 30 Amp	
	466492530S1	KZ Valve Driver	
	ARS MOUNTING HARDWARE		
	457141810	Hardware GC1000-S 1" Coupler	
	457141850	Hardware GC1000-S 1.25" Coupler	
	FLOW METERS		
	466491170S1	Pre Wet (0.3 - 5 GPM)	
	PM00370023S1	3/4" Poly (1.85 - 18.5 GPM)	
	PM00370030S1	1" Poly (2.64 - 26.4 GPM)	
	PM00370040S1	1.5" Poly (9.25 - 92.5 GPM)	
	PM00370048S1	2" Poly (19.0 - 198 GPM)	
	PM00370048S2	2" Poly w/1.5" Hose Barbs (19.0 - 198 GPM)	
	PM00370068S1	3" Poly (39.6 - 396 GPM)	
	466980040S1	Raven Flow Meter Adapter	
	TEMPERATURE SENSOR ADAPTERS		
	466494100S1	Road Watch SS	
	466492100S1	Surface Patrol	
	MISCELLANEOUS SENSORS		
	465700080S1	Down Pressure Hydraulic Sensor	
	466492370S1	Gate Height Sensor	
	VALVES		
	467092004S1	4 GPM Valve	
	467092008S1	8 GPM Valve	
	467092100	17/10 Hydraulic Valve	
	467092101	17/10 Hydraulic Valve Load Sense	
	467092110	34/10 Hydraulic Valve	
	467092111	34/10 Hydraulic Valve Load Sense	
	46709xxxx	PVC3000 Hydraulic Valve CALL FOR QUOTE	

Control Point®

CP Combo Liquid Parts Order List

Selecting System Components

CONTROL POINT® SYSTEM	PART NUMBER	DESCRIPTION
	VALVE & ACTUATOR ASSEMBLIES	
	467095010	Valve & Actuator Assembly 3/8" 2 way SS
	467095020	Valve & Actuator Assembly 1/2" 2 way SS
	467095030	Valve & Actuator Assembly 3/4" 2 way Poly
	467095300	Valve & Actuator Assembly 3/4" 2 way SS
	467095040	Valve & Actuator Assembly 1" 2 way CS
	467095280	Valve & Actuator Assembly 1" 2 way Poly
	467095290	Valve & Actuator Assembly 1" 2 way SS
	467095050	Valve & Actuator Assembly 1.5" 3 way Poly
	467095140	Valve & Actuator Assembly 1.5" 3 way SS
	467095150	Valve & Actuator Assembly 2" 2 way SS
	467095160	Valve & Actuator Assembly 2" 3 way SS
	467095170	Valve & Actuator Assembly 3" 2 way SS
	467095320	Valve & Actuator Assembly 1/4" 2 way SS
	LIQUID VALVE EXTENSION CABLES	
	457901820	Liquid Valve Extension Cable 15'
	457901821	Liquid Valve Extension Cable 30'
	KEYBOARD	
	466490850S1	Control Point® Programming Keyboard
	WIRELESS MISCELLANEOUS	
	466493400S1	Wireless Base Station (connects to office PC)
	466493400S2	Wireless Base Station and PC Software Kit
	466493500S1	100' External Antenna Cable
	466493600S1	External Antenna with Mounting Hardware
	EXT ANT KIT	External Antenna and 100' Antenna Cable Kit

Dual Flow



Use with 46421-0430S1
 PWM Granular Valve
 Drive Module

Dual Flow



The Dual Flow Spreader Control Valve provides proportional control of the spinner and conveyor/auger motor and can be mounted outside the cab. The valve is a direct replacement for the Fluid Control 2FFL 1 2 or equivalent spreader valve and can operate with either a fixed displacement or variable displacement (load sense) pump. Can also run continuously with the spinner circuit shutoff.

SPECIFICATIONS:

- Operating Pressure: Inlet 4,000 psi
- Regulated Flow Rate: 0-17 GPM or 0-34 GPM
 auger/conveyor
- 0-10 GPM Spinner
- Internal Leakage: 50 cc/min. max at 2,000 psi
- Coil Voltage: 12 VDC
- Max Control Current: 1,400 ± 100 mA

Part Number	Description
467092100	Dual Hydraulic Valve (HydraForce) 17 GPM conveyor/10 GPM spinner
467092101	Dual Hydraulic Valve (HydraForce) 17 GPM conveyor/10 GPM spinner Load Sense
467092110	Dual Hydraulic Valve (HydraForce) 34 GPM conveyor/10 GPM spinner
467092111	Dual Hydraulic Valve with Load Sense (HydraForce) 34 GPM conveyor/10 gpm spinner
467090421	Replacement Cartridge
467090360	Replacement Coil

P4, P8, P24

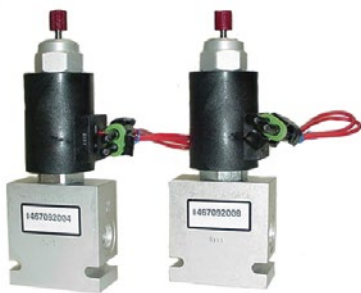

P4, P8, and P24

Proportional Flow Control Valves are electrical-variable two-way pressure-compensated spool valves and can be used with either open or closed-center hydraulics by plugging port 2 of the valve body.

SPECIFICATIONS:

- Operating Pressure: Inlet 3,500 psi (240 bar)
- Regulated flow rate: 0-4 GPM (0-15 LPM) p/n 46709-2004S1
 0-8 GPM (0-30 LPM) p/n 46709-2008S1
- Reverse Free Flow
 Cracking Pressure: 15-20 psi (1-1.4 bar)
- Internal Leakage: 0.10 GPM (0.38 LPM) at zero current
- Coil voltage: 12 VDC
- Max Control Current: 1,500 ± 100 mA
- Solenoid operated
- Normally closed when de-energized
- Three port

Port 1	Supply/In
Port 2	Bypass (Tank)
Port 3	Regulated

Part Number	Description
46709-2050S1	Valve Assembly 24 GPM
46709-2004S1	P4 Valve Assembly 4 GPM
46709-2008S1	P8 Valve Assembly 8 GPM
46709-0360S1	Replacement Coil (4 or 8 GPM Valve)
46709-0380S1	Replacement Cartridge 4 GPM
46709-0370S1	Replacement Cartridge 8 GPM

Hydraulic Servo Valve

Single Flow

Servo Hydraulic Flow Control Valves are used for precise oil flow to hydraulic-driven conveyors and liquid pumps.



The system must be in operation to make adjustments. Both adjustments are located under the center plate.

CAUTION: Be cautious to not overspeed the hydraulic motor.

Adjustment 1 (To eliminate creep)

1. Loosen the Allen head screw (large) in the coupling stem.
2. Using pliers, rotate the valve stem until creep stops to establish a closed position.
3. Retighten the Allen head screw in the coupling stem.

Adjustment 2 (Adjust maximum flow rate gpm)

1. Loosen the small Allen head screw in the orifice adjustment collar.
2. Using pliers, turn the orifice adjustment collar counterclockwise to increase flow; clockwise to decrease flow.
3. Retighten orifice collar screw.

Features:

- Close to open in 1.5 seconds
- Environmentally sealed
- Drives 3/8 to 1 in. liquid

Part Number	Description
15557-0001	Servo Valve 30 GPM 20 ft. cable 6 pin Weather Pack
15557-0004	Servo Valve 18 GPM 20 ft. cable 6 pin Weather Pack
15557-0011	Servo Valve 13 GPM 20 ft. cable 6 pin Weather Pack
15557-0013	Servo Valve 16 GPM 20 ft. cable 6 pin Weather Pack
15557-0015	Servo Valve 25 GPM 20 ft. cable 6 pin Weather Pack
15557-0016	Servo Valve 20 GPM 20 ft. cable 6 pin Weather Pack
15557-0021	Servo Valve 11 GPM 20 ft. cable 6 pin Weather Pack
15557-0022	Servo Valve 58 GPM 20 ft. cable 6 pin Weather Pack
15557-0023	Servo Valve 18 GPM (Ag Chem) 3 pin Metri Pack
15557-0024	Servo Valve 13 GPM (Ag Chem) 3 pin Metri Pack
15557-0025	Servo Valve 30 GPM (Ag Chem) 3 pin Metri Pack
15557-0026	Servo Valve 58 GPM (Ag Chem) 3 pin Metri Pack
46709-5360	Actuator only used on 15557-0001 to -0022. Requires hardware kit 46709-8040
46709-8040	Hardware Mounting Kit
46709-5350	Actuator only used on 15557-0023 to -0026. Requires hardware kit 46709-8040

Connector Pin Numbers ID		
Pin	Color	Function
A	Red	+12V
B	Black	Ground
C	White	Signal to open
D	Green	Signal to close
E	Blue	Feedback at open
F	N.C.	

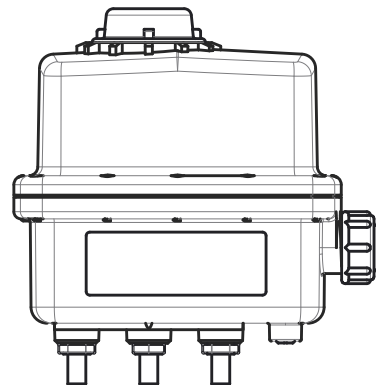

Actuator 46709-5350

Pre-Wet

Used for flow rate measurement of material applied.

GEM Flow Meter



GEM Flow Meter

Part Number	Description
46649117051	Flow Meter, GEM (comes with insertable orifice)
Flow rate with orifice	0.3 - 3 GPM
Flow rate without orifice	0.5 - 5 GPM
Output rate of 2,000 pulses per gallon	

Poly Flow Meter



Poly Flow Meter

Part Number	Description
PM00370023S1	3/4" Poly Flow Meter assembly
PM00370030S1	1" Poly Flow Meter assembly
PM00370040S1	1 1/2" Poly Flow Meter assembly
PM00370048S1	2" Poly Flow Meter assembly
PM00370048S2	2" Poly Flow Meter assembly with 1 1/2" hose barbs
PM00370068S1	3" Poly Flow Meter assembly
Flow Rate	
3/4"	1.85 - 18.5 GPM
1"	2.64 - 26.4 GPM
1 1/2"	9.25 - 92.5 GPM
2"	19.0 - 198 GPM
3"	39.6 - 396 GPM
3/4" - 2" Poly Flow Meter assemblies include:	
<ul style="list-style-type: none"> • Flow meter body with turbine, axle, and bearings • Hall-Effect sensor with 3-pin Weather Pack connector • 2 hose bars for inlet and outlet • 2 Viton o-ring • 2 coupling nuts 	

Poly Sensor and Parts



Poly Flow Meter

3" Poly flow meter assemblies include:

- Flow meter body with turbine, axle, and bearings
- Hall-Effect sensor with 3-pin Weather Pack connector
- 2 flanges with groove
- 2 Viton o-rings
- 2 flat flanges (no grooves)



Raven Flow Meter Adapter



Raven Fast Valve Adapter

Part Number	Description
467881000S1	Poly Flow Meter Sensor
PM29300725S1	1/2" Turbine
PM29301899S1	1/2" Axle and Bearings
PM65403132	1/2" Hose Barb (also fits 3/4" flow meter)
PM80001432	1/2" O-ring (Viton) (also fits 3/4" flow meter)
PM65401732	1/2" Coupling Nut (also fits 3/4" flow meter)
PM30301125S1	3/4" Turbine
PM30305099S1	3/4" Axle and Bearings
PM31300925S1	1" Turbine
PM31303199S1	1" Axle and Bearings
PM67402432	1" Hose Barb
PM80005432	1" O-ring (Viton)
PM67401332	1" Coupling Nut
PM34300325S1	1 1/2" Turbine
PM32302099S1	1 1/2" Axle and Bearings (same as 2")
PM82416432	1 1/2" Hose Barb
PM80004832	1 1/2" O-ring (Viton)
PM20005432	1 1/2" Coupling Nut
PM32300825S1	2" Turbine
PM32302099S1	2" Axle and Bearings (same as 1 1/2")
PM82412632	1 1/2" Hose Barb for 2" Flow Meter
PM82406532	2" Hose Barb
PM80002232	2" O-ring (Viton)
PM30005132	2" Coupling Nut
PM33302632	3" Flange with groove for O-ring
PM33302732	3" Flange, smooth
PM80009300	3" O-ring (Viton)
PM35300532	4" Flange with groove for O-ring
PM35300632	4" Flange, smooth
PM80002500	4" O-ring (Viton)

Adapter

Part Number	Description
466980040S1	Raven Flow Meter Adapter
466980100	Raven Fast Valve Adapter

Application Rate Sensors



Application Rate Sensor

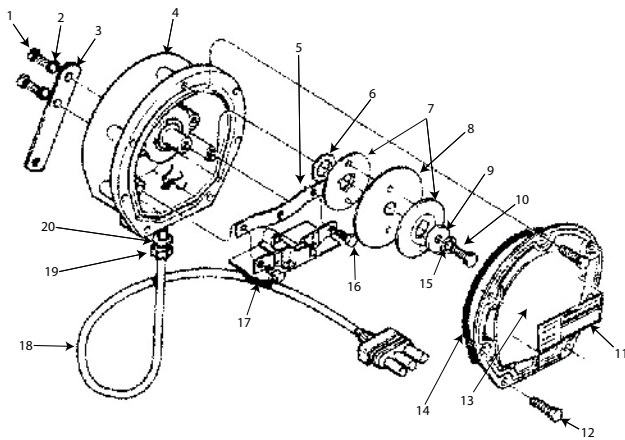

NOTE: All Rev. D sensors use an updated housing and bearing assembly and a different shaft seal. Shaft seal (not shown) is 21002-0011.

Cable Assembly		
	46436-0198	1 ft. Cable
	46436-0196	5 ft. Cable
	46436-0199	6 ft. Cable
	46436-0190	10 ft. Cable
	46436-0191	15 ft. Cable
	46436-0197	22 ft. Cable
	46436-0192	30 ft. Cable
Pin	Color	Function
A	Red	+12V
B	Black	Ground
C	Green	Signal

Auger/Conveyor sensors provide high resolution accuracy for measuring the rotational speed of a shaft to ensure system accuracy.

- Outputs at 360 pulses per revolution for increased accuracy
- RPM range 2-2,500
- Easily adapts to 1 and 1 1/4" diameter shafts
- 12V sensor with 5-8 V square-wave signal output

Part Number	Description
464360170S1	Application Rate Sensor 10' Cable WP
464360171S1	Application Rate Sensor 15' Cable WP
464360172S1	Application Rate Sensor 30' Cable WP
464360176S1	Application Rate Sensor 5' Cable WP
464360177S1	Application Rate Sensor 22' Cable WP
464360178S1	Application Rate Sensor 1' Cable WP
464211210S1	White Sensor Motor Adaptor

Item	Part Number	Description
1	20126-0013	PNH Tap Screw
2	20065-0012	#8 Lockwasher
3	42458	Mounting Bracket
4	46436-0161	Housing & Bearing Assembly (all but Rev. D)
4B	46436-0161B	Housing & Bearing Assembly (Rev. D only)
5	45714-1750	Grating Assembly
6	20000-0099	Stainless Steel Shim
7	45714-1050	Disk Retaining Washer
8	45714-0931	Slotted Disk, 360
9	20000-0098	Washer (1/8" thick)
10	20134-0040	#10-32 x 1/2" Hex Head Screw
11	20242-0088	Decal
12	21389-0030	#8 x 1/2" Stainless Steel Screw
13	45714-0920	Cover Plate
14	21028-0064	Sensor Plate O-ring
15	20032-0007	Internal Lockwasher
16	21389-0028	#6 x 1/2" Screw
17	46436-0200A	Circuit Board Assembly
18	Various	Cable Assembly
19	45382-2150	Nut Seal
20	21028-0040	O-ring
21	45714-0940A	Shaft (not shown)

Application Rate Sensors Accessories

Extension Harness



Extension Harness 15' 30', 45'

Part Number	Description
457901810	Extension Harness 15 ft.
457901811	Extension Harness 30 ft.
457901812	Extension Harness 45 ft.



1" Shaft Coupler



1 1/4" Shaft Coupler

Mounting Hardware

Part Number	Description
457141810	Mounting Hardware (includes 1" coupler)
457141850	Mounting Hardware (includes 1.25" coupler)



Tester

Tester

An Application Rate Sensor Tester quickly and effectively tests application rate sensors even when installed on the truck. The tester provides an audible alarm with each degree of rotation from the application rate sensor.

Part Number	Description
45007-0066	Application Rate Sensor Tester

Radar II & III

Radar II Sensors



Radar II

Part Number	Description
45640-1912S9	Radar II Kit with Mounting Brackets
45640-1912	Radar II Ground Speed Sensor only
45640-2090	Flat Radar Mounting Plate
45640-2100	Radar Pipe Mounting Bracket
43940-0024	10 ft. Ground Speed Sensor Extension

Radar III Sensors



Radar III

Part Number	Description
46783-1000S9	Radar III Kit with Mounting Brackets
46783-3000S1	Radar III only

Radar Connector Pinouts

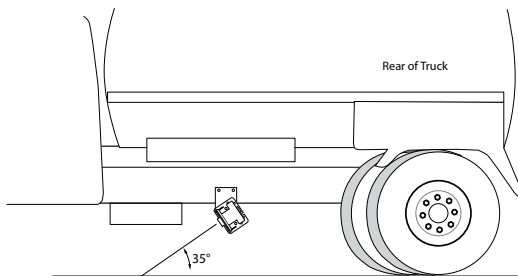

Radar Mounting Angle

Pin	Color	Function
1	Black	Ground
2	Green	Signal (sq. wave)
3	Red	+12V
4	Connected to Pin 3	Radar presence

Hall-Effect Sensors



Hall-Effect Sensor (smooth)



Hall-Effect Sensor (threaded)

Part Number	Description
46350-0030S1	Hall-Effect Speed Sensor (smooth)
46697-0014S1	Hall-Effect Speed Sensor (threaded)
20040-0089	Jam Nut for threaded Hall-Effect Sensor
46350-0120	Hall-Effect Sensor to Radar Extension 15.5 ft.

Mechanical/Electronic

Speedometers & Adapters



46421-0507S1

For use on Navistar and Ford trucks with automatic or manual non-World Transmissions. This adapter utilizes the Weather Pack connection on the transmission speed sensor to obtain a signal.



46421-0508S1

For use on trucks with automatic or manual non-World Transmissions. Use when direct connection to transmission speed sensor is not available and a splice connection to speed signal is required.



46317-0033S1

Navistar Adapter for use on Chevy, Dodge, Ford, and GMC 1 ton chassis with Weather Pack connectors. Connects to speed sensor in transmission. Converts sine wave to square wave speed signal.

Part Number	Description
439400024	10 ft. Ground Speed Sensor Extension
464210507S1	Electronic Speedometer Adapter Navistar (sine wave)
464210508S1	Electronic Speedometer Adapter Beede (Ford) (sine wave)
464210509S1	Electronic Speedometer Adapter (Metri Pack connector) (sine wave)
464211450	Electronic Speedometer Adapter (Deutch connector (sine wave)
464210520	Adapter Cable for Chevy Kodiak/GMC TopKick 1987-1990 (used with 46421-0507S1)
464210521	Adapter Cable for Chevy Kodiak/GMC TopKick 1987-1990 (used with 46421-0520)
464211440	Electronic Speedometer Adapter for World Transmission (sq. wave)
463170191	Electronic Speedometer Adapter (fly leads) (sq. wave)
463170192	Electronic Speedometer Adapter (ring terminals) (sq. wave)
466492130S1	Ground Speed Isolation Buffer
463170033S1	Navistar Truck Speed Adapter (Weather Pack connector) (sq. wave)
464211700	Flex 4 Adapter required with 46421-0507S1, 46421-0508S1, 46421-0509S1, 46421-1450

Electronic

Speedometer & Adapters



46421-0509S1

For use on trucks with an automatic or manual non-World Transmission and utilizes the Metri-Pack connection on the transmission speed sensor to obtain signal.



46317-0191

For use on trucks with an Allison World Transmission and connects to wire 157 of ECU module when "V20" is not available (fly leads).



46421-1450

For use on Navistar trucks with a manual transmission and connects to a speed sensor in the transmission via a Deutsch connector.

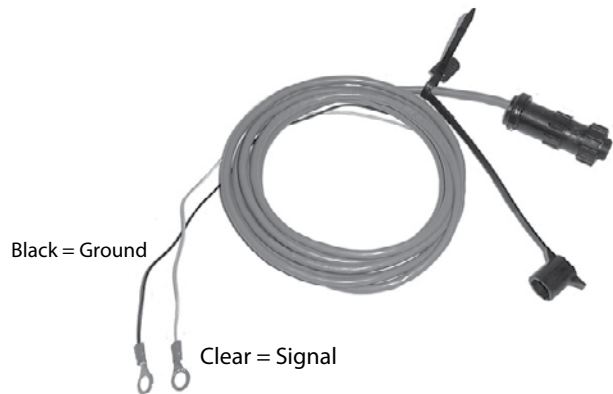

46317-0192

For use on trucks with an Allison World Transmission and connects to wire 157 of ECU module when "V20" is not available (ring terminals).



46421-1440

For use on trucks with an Allison World Transmission and connects direct to socket "V20" on ECU module.



46649-2130S1

For use on Navistar 5000/7000 Series trucks with the 12 VVW option. This adapter utilizes the fly lead connection on the engine compartment firewall to obtain a signal.

Hopper Level - Granular



Hopper Level Sensor with Mounting Bracket



Hopper Level Sensor

A hopper level sensor can be used to trigger an alarm when material falls below the sensor mounting level.

Part Number	Description
46421051851	Hopper Level Sensor with Mounting Bracket
46421087051	Hopper Level Sensor (Granular)
46421050651	Hopper Level Sensor Extension Harness 20 ft.

Connector Pin Outs Weather Pack		
Pin	Color	Function
A	Red	+12V
B	Black	Ground
C	Green	Signal (0-12V)
D		N.C.

Connector Pin Outs (46421-087051) Weather Pack		
Pin	Color	Function
A	Red	+12V
B	Black	Ground
C	Green	Signal
D		Plugged

SMD



(2) 2 pin Weather-Pack connector kit

(1) 16 pin Amp kit w/lock ring

Valve Driver SMD (46421-0430S1)

Used with granular PWM valves.

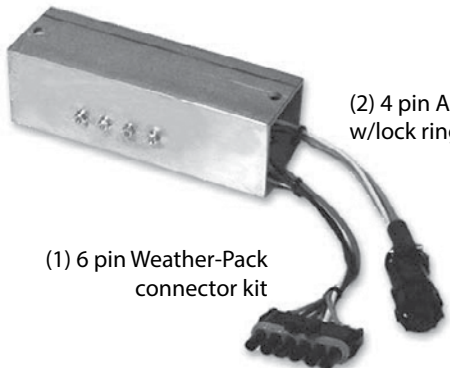

(2) 4 pin Amp kit w/lock ring

(1) 6 pin Weather-Pack connector kit

Hydraulic Valve Driver (46436-0030A)

Used with DICKEY-john® 15557-xxxx hydraulic valves. Requires an ICS/CCS adapter cable when used with ICS systems.



(2) 3 pin Amp kit with lock ring

(1) 6 pin Weather-Pack connector kit

Linear Valve Driver (46649-0920S1)

Used with Control Point to operate 12V liquid pump or PWM valve on hydraulic spraying system. Extension cable 46649-0960 on 46649-0961 required.

Item	Part Number	Description
	464210430S1	Valve Driver (SMD version)
1	110590013	Amp Kit with lock ring 16-pin
2	218950002	2 pin Weather Pack connector kit
3	218960002	Socket contact (not shown)
4	218940002	Connector plug (not shown)
5	200130032	Mounting bolts (not shown)

Connector Pin Outs		
Pin	Color	Function
6	Brown	Spinner open
8	White	Conveyor open
15	Black	Ground
16	Red	+12V

Connector Pin Outs (Conveyor/Auger)		
Pin	Color	Function
A	White	+12V
B	Gray	Ground
(Spinner)		
A	Brown	+12V
B	Black	Ground

Hydraulic

Item	Part Number	Description
	46436-0030A	Valve Driver (Hydraulic)
1	46627-0730	Weather-Pack connector kit 6-pin, flat
2	11059-0007	Amp kit with lock ring 4-pin
3	20013-0032	Mounting bolts (not shown)

Connector Pin Outs (Weather-Pack 6 pin)		
Pin	Color	Function
A	Red	+12V
B	Black	Ground
C	Brown	Open (0-12V)
D	White	Close (0-12V)
E	Gray	APER
F	NC	

Connector Pin Outs (Amp 4 pin)		
Pin	Color	Function
1	Yellow	Signal (0-12V)
2	NC	
3	Orange	Signal (0-12V)
4	Gray	APER

Linear

Item	Part Number	Description
	46649-0920S1	Valve Driver (Linear) max 15 amp
1	46627-0730	6 pin Weather-Pack connector kit , flat
2	11059-0023	3 pin AMP connector kit
3	20013-0032	Mounting bolts (not shown)

Connector Pin Outs (Weather-Pack)		
Pin	Color	Function
A	Red	+12V
B	Black	Ground
C	Brown	Actuator 1 (PWM)
D	NC	
E	NC	
F	NC	

Connector Pin Outs (AMP)		
Pin	Color	Function
1	Green	Signal (0-12V)
2	Black	Ground
3	NC	

PWM, Electric Pump, Liquid Servo

(2) 16 pin Amp connector kit



(1) 4 pin Weather-Pack connector kit

KZ Valve Driver (46421-0433S1)

Used with ICS1500 to operate KZ 3-way valve (95H-62-U). Adapter cable is required when used with Control Point (46649-2320).

Item	Part Number	Description
	464210433S1	Valve Driver (KZ)
1	466270720	4 pin Weather Pack connector kit
2	110590013	16 pin AMP connector kit

Connector Pin Outs (Weather-Pack)		
Pin	Color	Function
A	Black	Power (-)
B	Brown	Output B
C	White	Output A
D	Red	Power (+)
E	NC	
F	NC	

Connector Pin Outs (AMP)		
Pin	Color	Function
8	White	Output A
9	Brown	Output B
15	Black	Power (-)
16	Red	Power (+)

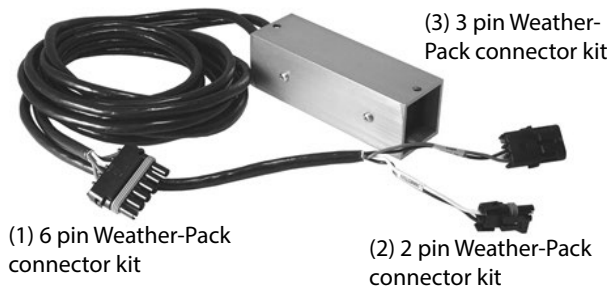

(1) 6 pin Weather-Pack connector kit

(2) 2 pin Weather-Pack connector kit

(3) 3 pin Weather-Pack connector kit

KZ Valve Driver w/Limit Switch (46649-2530S1)

Used with F6H-50-Y K2 Valve to indicate valve full open.

Item	Part Number	Description
	466492530S1	Valve Driver (KZ) w/limit switch
1	466270730	6 pin Weather Pack connector kit
2	466270250	2 pin Weather Pack connector kit
3	466270260	3 pin Weather Pack connector kit

Connector Pin Outs (Weather-Pack)		
Pin	Color	Function
A	Red	12V
B	Black	Ground
C	White	Input A
D	Brown	Input B
E	Gray	Control
F	NC	

Connector Pin Outs (Weather-Pack)		
Pin	Color	Function
A	Brown	Output A
B	White	Output A Return

Connector Pin Outs (Weather-Pack)		
Pin	Color	Function
A	NC	
B	Black	Output B
C	Gray	Output B Return



(1) 4 pin Weather-Pack connector kit

(2) 3 pin Weather-Pack connector kit

12V Relay (46436-0032)

Used with Control Point to shutoff the main boom valve simultaneously with liquid channel requirements.

Item	Part Number	Description
	464360032	Relay 12V
1	466270710	4 pin Weather Pack connector kit
2	466270260	3 pin Weather Pack connector kit

Connector Pin Outs (Weather-Pack)		
Pin	Color	Function
A	Red	12V
B	Black	Ground
C	Brown	Switched 12V
D	NC	

Connector Pin Outs (Amp)		
Pin	Color	Function
A	Orange	Output sw 12V
B	Yellow	Ground
C	Red	12V

Linear

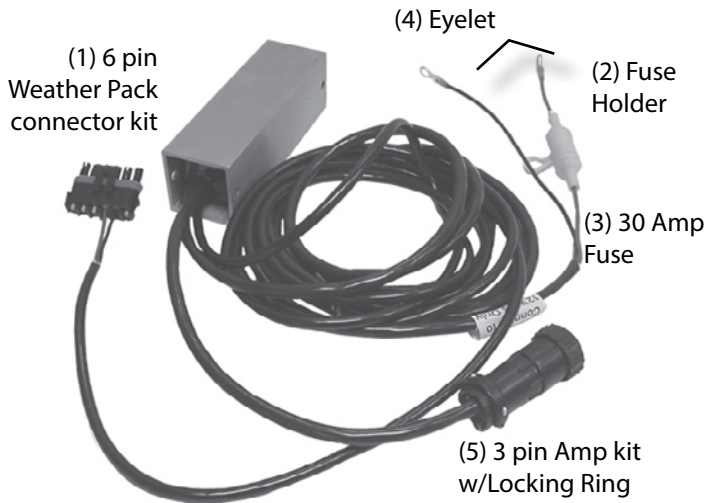

Linear Valve Driver

Used with Control Point, ICS, and CCS products to operate an electric motor when current requirements are greater than 15 amps. Direct battery connection required. Max 30 amps

Item	Part Number	Description
	464900010S1	Valve Driver (Linear) max 30 Amp
1	466270730	6 pin Weather Pack connector kit , flat
2	201080014	Fuse holder
3	201120006	30 Amp Fuse
4	200040010	Eyelet, 5/16" ring terminal ins.
5	110590023	3 pin Amp connector kit
6	200130032	Mounting bolts (not shown)

Connector Pin Outs (Weather-Pack 6 pin)		
Pin	Color	Function
B	Black	Ground
C	Brown	Actuator 1 (PWM)
D	NC	
E	NC	
F	NC	

Connector Pin Outs (AMP 3 pin)		
Pin	Color	Function
1	Green	Signal (0-12V)
2	Black	Ground
3	NC	

Eyelets (Ring Terminals)	
Color	Function
Red	+12V
Black	Ground

Adapter Cable

Part Number	Description
466390180	Banjo Regulating Valve Driver Adapter Cable used w/46436-0030A

Two-Way, Stainless Steel

Two-way regulating control valves, stainless steel, available in 3/8 in., 1/2 in., 3/4 in., 1 in., 2 in., and 3 in.



2 way Stainless Steel Valve with 46709-5070 Actuator 3/8", 1/2"



2 way Stainless Steel Valve with 46709-5060 Actuator 1", 3/4" 2"



2 way Stainless Steel Valve with 46709-5250 Actuator 3"



2 way Poly Valve with 46709-5070 Actuator 3/4", 1"



2 way Stainless Steel Valve 467095320 1/4"

Valve Parts			
Part Number	Valve Size (Inches)	Flow Rate GPM	Description
46709-5010	3/8	6	Stainless Steel Valve, 2 way with 46709-5075 Actuator
46709-5020	1/2	30	Stainless Steel Valve, 2 way with 46709-5075 Actuator
46709-5290	1	68	Stainless Steel Valve, 2 way with 46709-5060 Actuator
46709-5150	2	376	Stainless Steel Valve, 2 way with 46709-5060 Actuator
46709-5170	3	720	Stainless Steel Valve, 2 way with 46709-5250 Actuator
46709-5320	1/4	8.4	Stainless Steel Valve, 2 way with 46709-5070 Actuator

Two-way Poly regulating control valves available in 3/4 in., 1 in.

Valve Parts			
Part Number	Valve Size (Inches)	Flow Rate GPM	Description
46709-5030	3/4	51	Poly Valve, 2 way with 46709-5070 Actuator
46709-5280	1	68	Poly Valve, 2 way with 46709-5070 Actuator

Two-way regulating control valve, carbon steel, available in 1 in.

Valve Parts			
Part Number	Valve Size (Inches)	Flow Rate GPM	Description
46709-5040	1	68	Carbon Steel Valve, 2 way with 46709-5060 Actuator

Liquid Servo Valve Extensions

Part Number	Description
45790-1820	Extension Cable 15 ft. 6 pin WP
45790-1821	Extension Cable 30 ft. 6 pin WP



2 way Carbon Steel Valve with 467095060 Actuator 1"

Connector Pin Numbers ID		
Pin No.	Color	Function/ Voltage
A	Red	+12V
B	Black	Ground (0V)
C	White	Open (0-12V)
D	Green	Close (0-12V)
E	Blue	APER (0-12V)
F	N.C.	



Liquid Servo Valve Extension

Three Way

Three-way regulating control valve assemblies available in 1.5", 2".



3 way Stainless Steel Valve with 46709-5370 Actuator 1 1/2"

Valve Parts			
Part Number	Valve Size (Inches)	Flow Rate GPM	Description
46709-5050	1.5	47	Poly Valve, 3 way Poly with 46709-5370 Actuator
46709-5140	1.5	103	Stainless Steel Valve, 3 way with 46709-5370 Actuator
46709-5160	2	143	Stainless Steel Valve, 3 way with 46709-5250 Actuator



3 way Stainless Steel Valve with 46709-5250 Actuator 2"

Connector Pin Numbers ID		
Pin No.	Color	Function/Voltage
A	Red	+12V
B	Black	Ground (0V)
C	White	Open (0-12V)
D	Green	Close (0-12V)
E	Blue	APER (0-12V)
F	N.C.	

Raven Fast Valve Adapter Harness

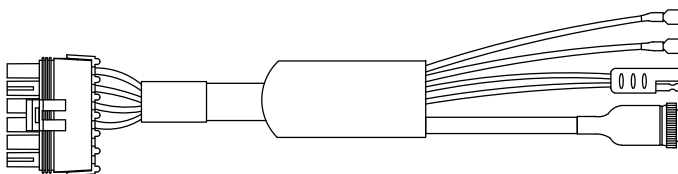

**Raven Fast Valve Adapter Harness
466980100**

Adapter Harness	
Part Number	Description
46698-0100	Raven Fast Valve Adapter Harness
46698-0040S1	Raven Flow Meter Adapter Harness



Single Liquid Shutoff Valve
467096000 3/4"



3 Bank Shutoff Valve
467096010 3/4"



5 Bank Shutoff Valve
467096020 3/4"



Single Shutoff Valve
467095130 1"



467097020



467097030



467097040



467097050



467097060



467097070



467097080



467097090

Liquid Boom Shutoff

Liquid Boom Shutoff Valves (on/off) available in 3/4 in. and 1 in.

Actuators Only			
Part Number	Valve Size (Inches)	Used With	Description
46709-6030	3/4	46709-6000 46709-6010 46709-6020	Actuator Assembly EH5 On/Off
46709-5260	1	46709-5130	Actuator Assembly Shutoff Valve
46709-6060	3/4	46709-6040	Actuator Assembly EH22

Liquid Shutoff Valves

Valve Assemblies			
Part Number	Valve Size (Inches)	Flow Rate GPM	Description
46709-6000	3/4	40	Single Shutoff Valve and Actuator
46709-6010	3/4	38	3 Bank Shutoff Valve and Actuator
46709-6020	3/4	38	5 Bank Shutoff Valve and Actuator

Boom Shutoff Valve Fittings

Boom Shutoff Valve Fittings		
Part Number	Hose Size (Inches)	Description
46709-7020	1/2	Boom Shutoff Valve Fitting, straight
46709-7030	1/2	Boom Shutoff Valve Fitting, 90 degree
46709-7040	3/4	Boom Shutoff Valve Fitting, straight
46709-7050	3/4	Boom Shutoff Valve Fitting, 90 degree
46709-7060	3/4	Boom Shutoff Valve Fitting, female NPT
46709-7070	1	Boom Shutoff Valve Fitting, straight
46709-7080	1	Boom Shutoff Valve Fitting, 90 degree
46709-7090	1	Boom Shutoff Valve Fitting, male NPT

Liquid Valve Bodies

Valve body without actuator available in 3/8", 1/2", 3/4", 1", 1.5", 2", and 3".

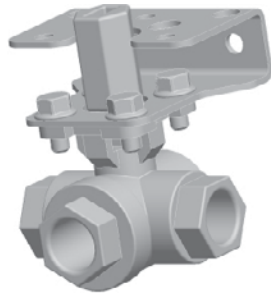

3 way Stainless Steel Valve (3/8" 46709-5230)

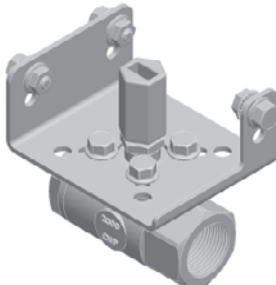

**2 way Stainless Steel Valve (3/8" 46709-5080)
(1/2" 46709-5090) (3/4" 46709-5310) (1" 46709-5290)**



2 way Poly Valve (3/4" 46709-5100) (1" 46709-5180)

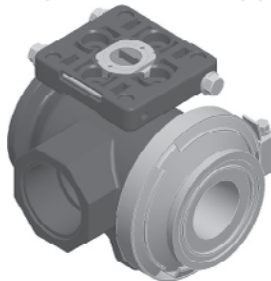

3 way Poly Valve (1.5" 46709-5120)

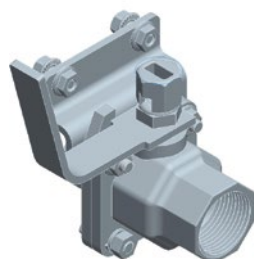

2 way Carbon Steel (1" 46709-5110)

Part Number	Valve Size	Description
467095080	3/8"	Stainless Steel Valve, 2 way
467095230	3/8"	Stainless Steel Valve, 3 way
467095090	1/2"	Stainless Steel Valve, 2 way
467095310	3/4"	Stainless Steel Valve, 2 way
467095100	3/4"	Poly Valve, 2 way
467095110	1"	Carbon Steel Valve, 2 way
467095180	1"	Poly Valve, 2 way
467095120	1.5"	Poly Valve, 3 way
467095190	1.5"	Stainless Steel Valve, 3 way
467095200	2"	Stainless Steel Valve, 2 way
467095210	2"	Stainless Steel Valve, 3 way
467095240	3"	Stainless Steel Valve, 2 way
457903380	1 1/4"	Ball Valve (NH3)

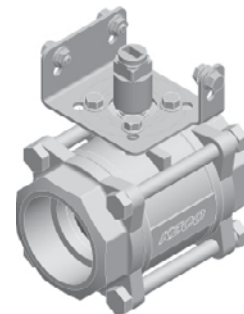

2 way Stainless Steel Valve (2" 46709-5200) (3" 46709-5240)

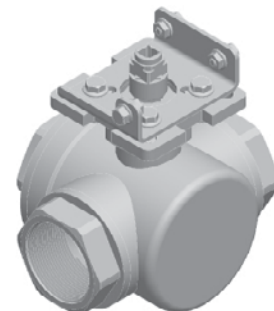

3 way Stainless Steel Valve (1.5" 46709-5190) (2" 46709-5210)

Ball Valve (NH3) 1.25"

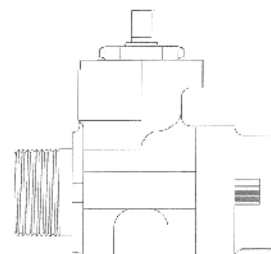

Actuator Assemblies

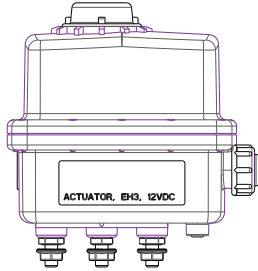

Actuator Assembly (46709-5070)

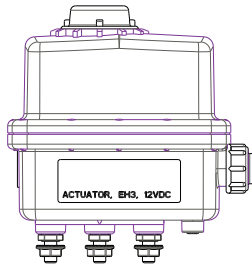

Actuator Assembly (46709-5075)

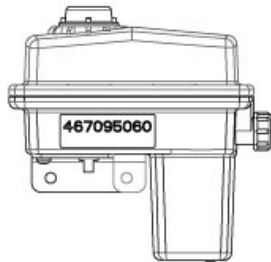

Actuator Assembly (46709-5060)

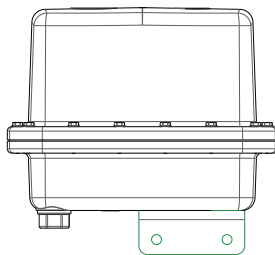

Actuator Assembly (46709-5250)

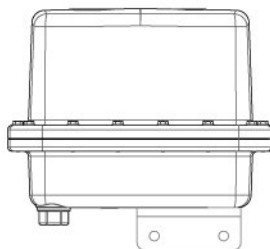

Actuator Assembly (Shutoff Valve) (46709-5260)

Part Number	Used With Valve	Description
46709-5060	46709-5310 46709-5110 46709-5120 46709-5190 46709-5200 46709-5290	Actuator Assembly EH2
46709-5070	46709-5100 46709-5180 46709-5330	Actuator Assembly EH3
46709-5075	46709-5080 46709-5230 46709-5090	Actuator Assembly EH3
46709-5250	46709-5210 46709-5240	Actuator Assembly EH5
46709-5260	46709-6000 46709-6010 46709-6020	Actuator Assembly EH5 On/Off
46709-6030	46709-5130	Actuator Assembly Shutoff Valve
46709-5065	56709-5110	Actuator Assembly EH22
46709-5370	46709-5120 46709-5190	Actuator EH2



10' Ground Speed Extension



7' Sensor Extension



15' Liquid Valve Extension



20' Hopper Level Extension

Part Number	Description
43940-0024	Ground Speed Extension 10' (4 pin)
45790-1810	Sensor Extension Cable 15' (3 pin)
45790-1811	Sensor Extension Cable 30' (3 pin)
45790-1812	Sensor Extension Cable 45' (3 pin)
45790-1813	Sensor Extension Cable 7' (3 pin)
45790-1820	Liquid Valve Extension 15' (6 pin)
45790-1821	Liquid Valve Extension 30' (6 pin)
46421-050651	Sensor Extension 20' (4 pin square)
46421-051251	Valve/Driver Extension 10' (16 pin)
46421-051351	Valve/Driver Extension 20' (16 pin)
46421-051451	Valve/Driver Extension 30' (16 pin)
46421-1180	Dual PWM Valve Extension 2 15' (2 pin connectors)
46421-1460	Dual Sensor Extension 2 30' (3 pin connectors)



10' Valve Driver Extension



15' Dual PWM Valve Extension 2

Universal Proportional



Ground Speed



Control Point



ICS

The Universal Proportional Simulator allows demonstration of a Control Point, ICS1100, ICS1500, ICS2000, or LT Control and simulates ground speed and feedback of application rate sensors, flow meter, etc. Appropriate adapter cable required.

Part Number	Description
46790-0010S1	Universal Proportional Simulator
46790-0050	Control Point UPS Adapter Cable
46790-0060	ICS UPS Adapter Cable
46790-0090	LT Control UPS Adapter Cable

Flex4 Pro Simulator

The Flex4 Pro Simulator allows demonstration of a Flex4 Pro system and simulates ground speed and feedback of application rate sensors, flow meter, etc. Appropriate adapter cable required.

Part Number	Description
	Contact Technical Support at 1-800-637-3302

Ground Speed

A Ground Speed simulator generates a ground speed signal useful for troubleshooting.



Part Number	Description
45640-4511S1	Ground Speed Simulator VGS-200

Manuals and Installation Instructions

Part Number	Description
11001-0950	ICS2000 Ice Control System Operator's Manual
11001-0958	ICS2000 Calibration & Programming Operator's Manual
11001-0972	ICS2000 French Canadian Operator's Manual
11001-0993	ICS2000 French Canadian Calibration & Programming Operator's Manual
11001-1042	ICS2000 Instruction with Printer
11001-1172	ICS1500 Calibration & Programming Operator's Manual
11001-1183	ICS1100 Operator's Manual
11001-1211	DART PC Tools Manual Addendum
11001-1323	LT Control Operator's Manual
11001-1332	Control Point Operator's Manual
11001-1391	Control Point Wireless Instruction
11001-1462	Control Point Wireless Antenna Kit
11001-1575	Flex4 Quick Start Guide
11001-1576	Flex4 Operator's Manual
11001-1609	Flex4 Report Generator Tool Instruction
11001-1621	Flex4 Ground Speed Adapter Cable Instruction
6010541	Flex4 Pro Operator's Manual
11001-1640	Hydraulic Control Valve Instruction
11001-1642	KZ Co Hydraulic Valve Actuator Mounting Hardware
11001-1621	Flex4 Connector Groud Speed Adapter Cable

Sales Literature

Part Number	Description
5002001	Radar II
5002001	Radar III
11071-0228A	Control Point
5001821	Application Rate Sensor
11071-0268	ICS2000
11071-0271	HydraForce PWM Valve
11071-0272	LT Control
11071-0340	PVC3000
11071-0356	Control Point Wireless
11071-0403	Flex4
5001891	Flex 4 Pro
11071-0414	Public Works Product Catalog

Service parts are available in limited quantities.
Contact the technical support team for availability
at 1-800-637-3302.

Products contained in the Service Parts section include:

- Flex4™
- Flex4 Pro™
- LT Spreader Control
- ICS2000
- Control Point
- Multi-Function Joystick
- PVC3000 Hydraulic Valve
- Hydraulic Servo Valve
- Speed-o-Meter Adapter
- Pressure Sensor - Liquid
- Connectors and Kits
 - Weather Pack
 - Amp, ITT Cannon
 - Deutsch

Flex4™

System Diagram

HARDWARE REQUIREMENTS

The Flex4 console interfaces and operates with the following components:

- Remote rate control module that receives all sensor inputs and valve drive outputs
- Remote operator switch module that incorporates a system master auto on/off switch, spinner/spread width adjustment rotary knob, material rate increase/decrease switches, blast and pause switch
- Optional member output module for boom shutoff and gate height adjustment

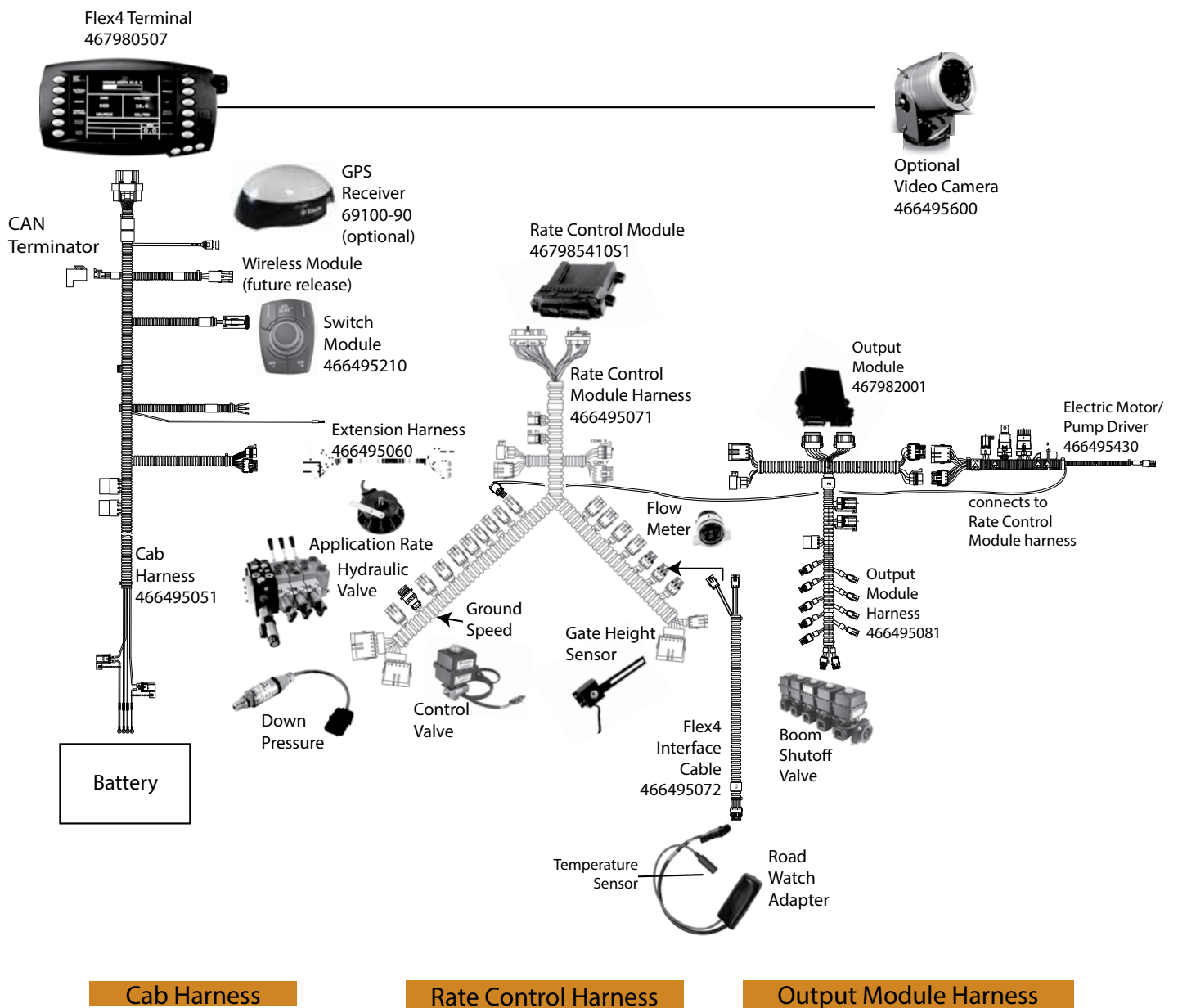

Flex4™

System Wiring Diagram

CONN 1 - BLACK

Pin	Function
6	F2 Fuse
7	Ground
2	Boom Output 1
3	CAN High
10	CAN Low
11	Boom Output 2
1	Gate Height
12	Gate Height
4	Plug NA
5	Plug NA
8	Plug NA
9	Plug NA

CONN H - GRAY

Pin	Function
8	F1 Fuse
5	F1 Fuse
7	Ground
6	Ground
11	Boom Output 6
10	Boom Output 5
2	Boom Output 4
3	Boom Output 3
1	Relay Socket 85
4	Conveyor Right
12	Conveyor Left
9	Auger Reverse

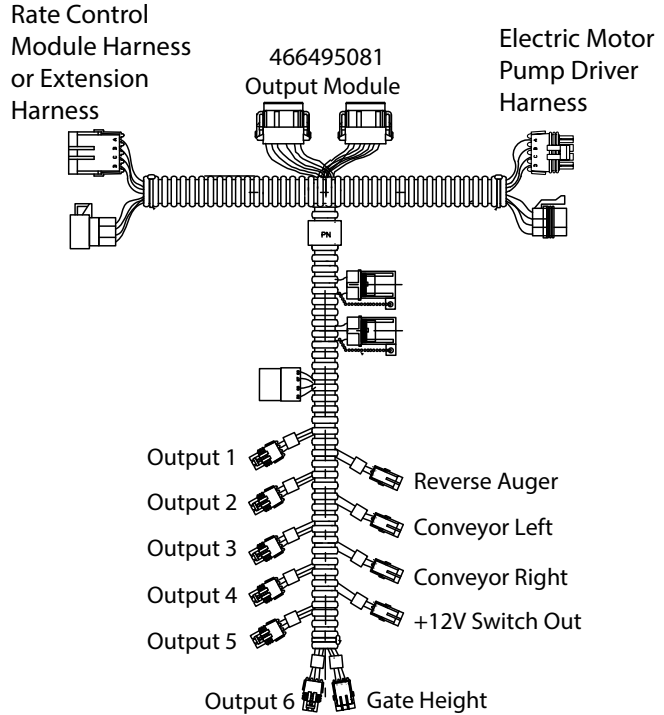

CONN A

Pin	Function
C3	Joystick Switch Input
H1	Servo Aux Open
G1	Servo Aux Close
F2	Servo Aux Aper
A1	Servo Liquid Open
C1	Servo Liquid Close
G3	Servo Liquid Aper
B3	Remote 12V Out
A3	Ground Speed
E1	Granular Feedback
E2	Aux Feedback
D3	Liquid Feedback
A2	Spinner Feedback
B1	Liquid PWM
J1	Aux PWM
D1	Granular PWM
K1	Spinner PWM
G2	Solenoid Ground
H3	Solenoid Ground
H2	Solenoid Ground
J3	Solenoid Power
K3	Solenoid Power
K2	Solenoid Power
F1	ECU Power
F3	ECU Ground
B2	CAN Low
C2	CAN High
E3	Plug NA
D2	Plug NA
J2	Plug NA

CONN B

Pin	Function
E3	Analog 2
C2	Analog 3
D2	Analog 4
B3	Analog 1
E1	Boom Sense 1
B2	Boom Sense 2
F1	Boom Sense 3
F2	Boom Sense 4
F3	Boom Sense 5
A2	Boom Sense 6
D1	Remote Blast
C1	Hopper Level
B1	Digital 2
A1	Digital 1
D3	Plug NA
C3	Plug NA
E2	Plug NA
A3	Plug NA

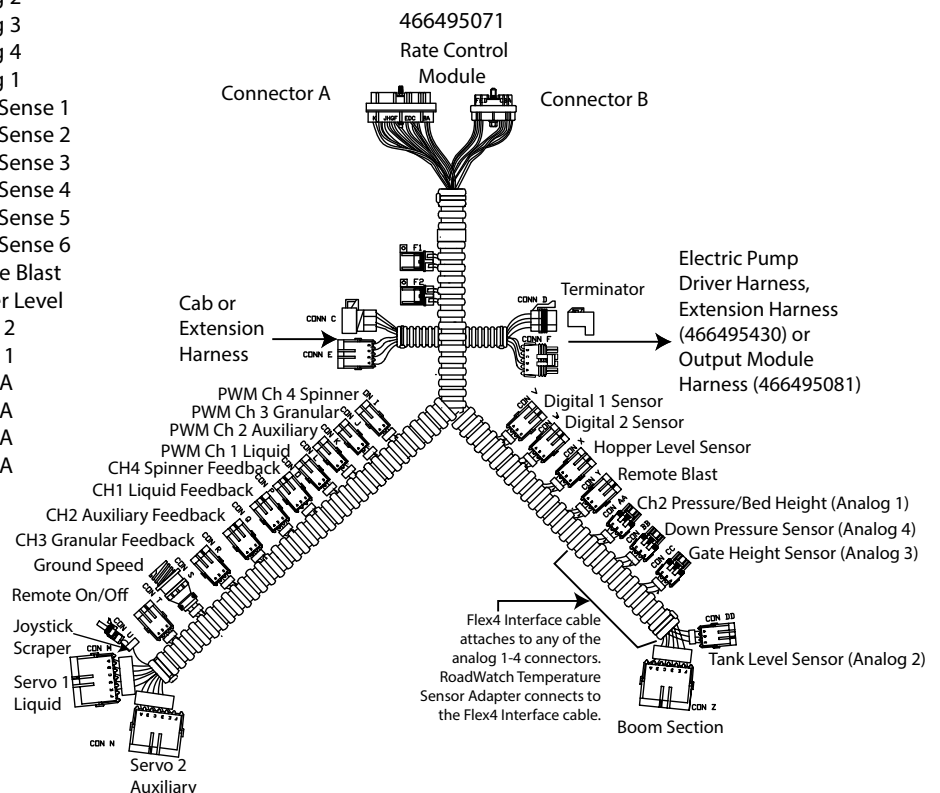

Flex4™



Flex4 Terminal and
Operator Remote Switch Module

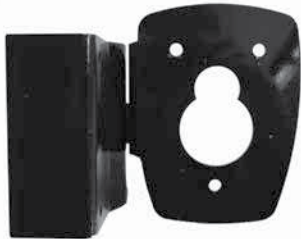

Optional Remote
Switch Mounting
Bracket



RAM Mount Kit



Cab/Power Harness



WSMT2 Rate Control
Module Harness

Operator Interface and System Kit

The terminal and operator remote switch module are installed in the cab for control of material application.

Terminal features a 7" color display that provides simultaneous viewing of:

- Rates
- Spread width
- Vehicle speed
- Spread direction
- Road temperature
- Joystick selection
- Accessory input monitoring

Additional Features:

- Video camera connection
- USB RS232 port for data download and keyboard connection

Operator remote switch module consists of buttons that control material application rate and a spread width knob to adjust spinner speed and regulate spreading of material. The module is backlit for visibility during night operation.

The Flex4COMBO kit includes the terminal, module, and required components for system operation. Additional components are available for added functionality.

FLEX4 System	
Part Number	Description
FLEX4COMBO Kit contains one each of the below components.	
466495210	Operator Switch Module
466495051	Cab Power Harness
466495071	WSMT2 Rate Control Module Harness
467980507	Console
466495100	Switch Module to Console Mounting Hardware
467980624	RAM Mount Kit (attaches terminal to vehicle dash)
46798541051	WSMT2 Rate Control Module
464211700	Flex4 Ground Speed Adapter Cable (required for use ONLY with certain electronic ground speed sensors, see page 6)
11001-1576	Operator's Manual

Remote Switch Module Mounting Kit

An optional operator remote switch module mount (sold separately) mounts the switch module to the driver seat armrest.

Part Number	Description
466495130	Remote switch module mounting kit (Optional)

Flex4™

Parts Order List

To order a Flex4 system, the following information is required to ensure the proper system is selected for the correct application. Any Flex4 systems ordered require a calibration keyboard for entry of calibration and programming data. One keyboard, p/n 466490850S1, can be shared among multiple trucks.

FLEX4 SYSTEM		PART NUMBER	DESCRIPTION
Flex4 Base kit includes one each of parts included in the highlighted box.	FLEX4COMBO	Flex4 System Base Kit	
	466495210	Operator Switch Module	
	466495051	Cab/Power Harness	
	466495071	WSMT Harness	
	467980507	Flex4 Terminal	
	466495100	Switch Module to Terminal Mounting Hardware	
	467980624	Flex4 RAM Mount Kit	
467985410	WSMT2 Control Module		
ACCESSORIES			
466495060	10' CAN Extension		
466495081	WSMB Output Harness		
466492101	WSMB Output Module		
466495600	Camera 4.3mm Lens		
466495610	Flex4 Camera Adapter		
466495620	20' Camera Extension		
SPEED SENSORS (select 1)			
464210507S1	El Speedo Navistar Sine Wave		
464210508S1	El Speedo Ford Sine Wave		
464210509S1	El Speedo w/Metri Pack Connectors Sine Wave		
464211450	El Speedo Navistar w/Deutsch Connectors Sine Wave		
464211440	El Speedo World Trans ECU V20 Socket Conn Sq Wave		
463170192	El Speedo World Trans Wire 157 Sq Wave		
463170191	El Speedo World Trans Wire 157 Sq Wave		
466492130S1	El Speedo Navistar 5000/7000 12 VVW Option		
467831000S9	Radar III with Mounting Hardware		
APPLICATION RATE SENSORS (select 1)			
464360170S1	Application Rate Sensor 10' Cable		Which application rate sensor or adapter is required.
464360171S1	Application Rate Sensor 15' Cable		
464360172S1	Application Rate Sensor 30' Cable		
464360176S1	Application Rate Sensor 5' Cable		
464360177S1	Application Rate Sensor 22' Cable		
464360178S1	Application Rate Sensor 1' Cable		
ARS/FLOW METER EXTENSION OPTIONS (select 1)			
457901810	Extension Cable 15'		What is the correct cable length required for the flow meter and/or application rate sensor.
457901811	Extension Cable 30'		
457901812	Extension Cable 45'		
ARS MOUNTING HARDWARE (select 1)			
457141810	Hardware GC1000-S 1" Coupler		
457141850	Hardware GC1000-S 1.25" Coupler		
VALVE EXTENSION OPTION (select 1)			
464211180	Dual PWM Valve Extension Harness 15'		Extension option for PWM Valve Driver 464210430S1.
HIGH CURRENT ELECTRIC MOTOR DRIVERS			
466495430	Electric Motor/Pump Driver		
OPTIONS			
FLOW METERS			
466491170S1	Pre Wet (0.3 - 5 GPM)		
PM00370023S1	3/4" Poly (1.85 - 18.5 GPM)		
PM00370030S1	1" Poly (2.64 - 26.4 GPM)		
PM00370040S1	1.5" Poly (9.25 - 92.5 GPM)		
PM00370048S1	2" Poly (19.0 - 198 GPM)		
PM00370048S2	2" Poly w/1.5" Hose Barbs (19.0 - 198 GPM)		
PM00370068S1	3" Poly (39.6 - 396 GPM)		
466980040S1	Raven Flow Meter Adapter		
TEMPERATURE SENSOR ADAPTERS			
466494100S1	Road Watch SS		
466492100S1	Surface Patrol		
466495072	Flex4 Interface Cable (required with RoadWatch)		
MISCELLANEOUS SENSORS			
465700080S1	Down Pressure Hydraulic Sensor		
466492370S1	Gate Height Sensor		
GPS RECEIVER			
69100-90	GPS Receiver Kit (Receiver, Cable Assy, Mounting Plate, Reference Guide)		

Flex4™

Parts Order List

Selecting System Components

FLEX4 SYSTEM	
PART NUMBER	DESCRIPTION
VALVES	
467092004S1	4 GPM Valve
467092008S1	8 GPM Valve
467092100	17/10 Hydraulic Valve
467092101	17/10 Hydraulic Valve Load Sense
467092110	34/10 Hydraulic Valve
467092111	34/10 Hydraulic Valve Load Sense
VALVE & ACTUATOR ASSEMBLIES	
467095010	Valve & Actuator Assembly 3/8" 2 way SS
467095020	Valve & Actuator Assembly 1/2" 2 way SS
467095030	Valve & Actuator Assembly 3/4" 2 way Poly
467095300	Valve & Actuator Assembly 3/4" 2 way SS
467095040	Valve & Actuator Assembly 1" 2 way CS
467095280	Valve & Actuator Assembly 1" 2 way Poly
467095290	Valve & Actuator Assembly 1" 2 way SS
467095050	Valve & Actuator Assembly 1.5" 3 way Poly
467095140	Valve & Actuator Assembly 1.5" 3 way SS
467095150	Valve & Actuator Assembly 2" 2 way SS
467095160	Valve & Actuator Assembly 2" 3 way SS
467095170	Valve & Actuator Assembly 3" 2 way SS
467095320	Valve & Actuator Assembly, 1/4" 2 way SS
LIQUID VALVE EXTENSION CABLES	
457901820	Liquid Valve Extension Cable 15'
457901821	Liquid Valve Extension Cable 30'
KEYBOARD	
466495630S1	Programming Keyboard with decal
466495630	Programming Keyboard only

Flex4 Pro™

Features



The Flex4 Pro is a four-channel system that can control a combination of liquid (pre-wet and de-icing) and granular materials simultaneously. Changes from pre-wet to anti-ice application from inside the truck are accomplished with a simple press of a button eliminating the time required to get out and change hydraulic hoses.

Boom section control is integrated into the console providing on/off boom section control for up to six sections.

Expanding capabilities beyond the winter months, the Flex4 Pro can be used for roadside weed control and spreading rock on roadside edges with appropriate units of measurement.

Control channels can be programmed for manual control to operate hydraulic tools such as:

- front-mounted sweepers
- jack hammers
- hydraulic ramps
- cross conveyors for roadside berming

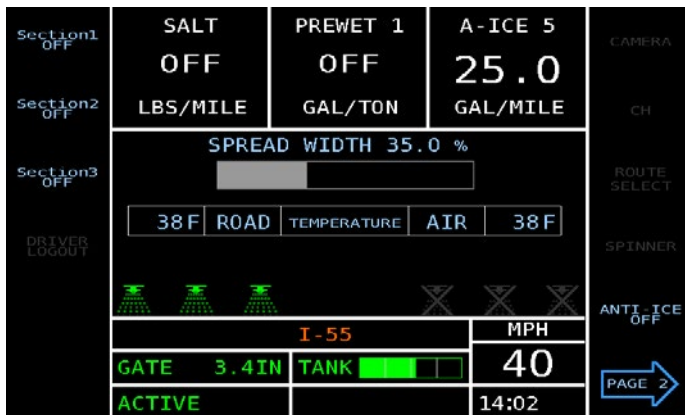

FEATURES:

- 10.1" high resolution Display
- Simultaneous display of 3 product application rates
- Six boom section control buttons
- Anti-ice button automatically turns granular and liquid channels off to spread anti-ice material
- Entry of 20 preset routes and 10 operator ID's
- Camera port connection to interface with a remote mounted camera
- Manual and ground speed override
- Two customizable sensor inputs for monitoring truck accessories
- Optional video camera to monitor truck activity and prevent accidents
- Import/export of configuration files for system upgrades and data download

Don't forget to select a:

- Speed sensor
- Application rate sensor
- Temperature sensor
- Down pressure sensor
- Flow meter
- Electric motor driver
- Control valve
- Gate height sensor
- Output module
- Extension harnesses



Flex4 Pro™

System Diagram

HARDWARE REQUIREMENTS

The Flex4 Pro console interfaces and operates with the following components:

- Remote rate control module that receives all sensor inputs and valve drive outputs
- Remote operator switch module that incorporates a system master auto on/off switch, spinner/spread width adjustment rotary knob, material rate increase/decrease switches, blast and pause switch
- Optional member output module for boom shutoff and gate height adjustment

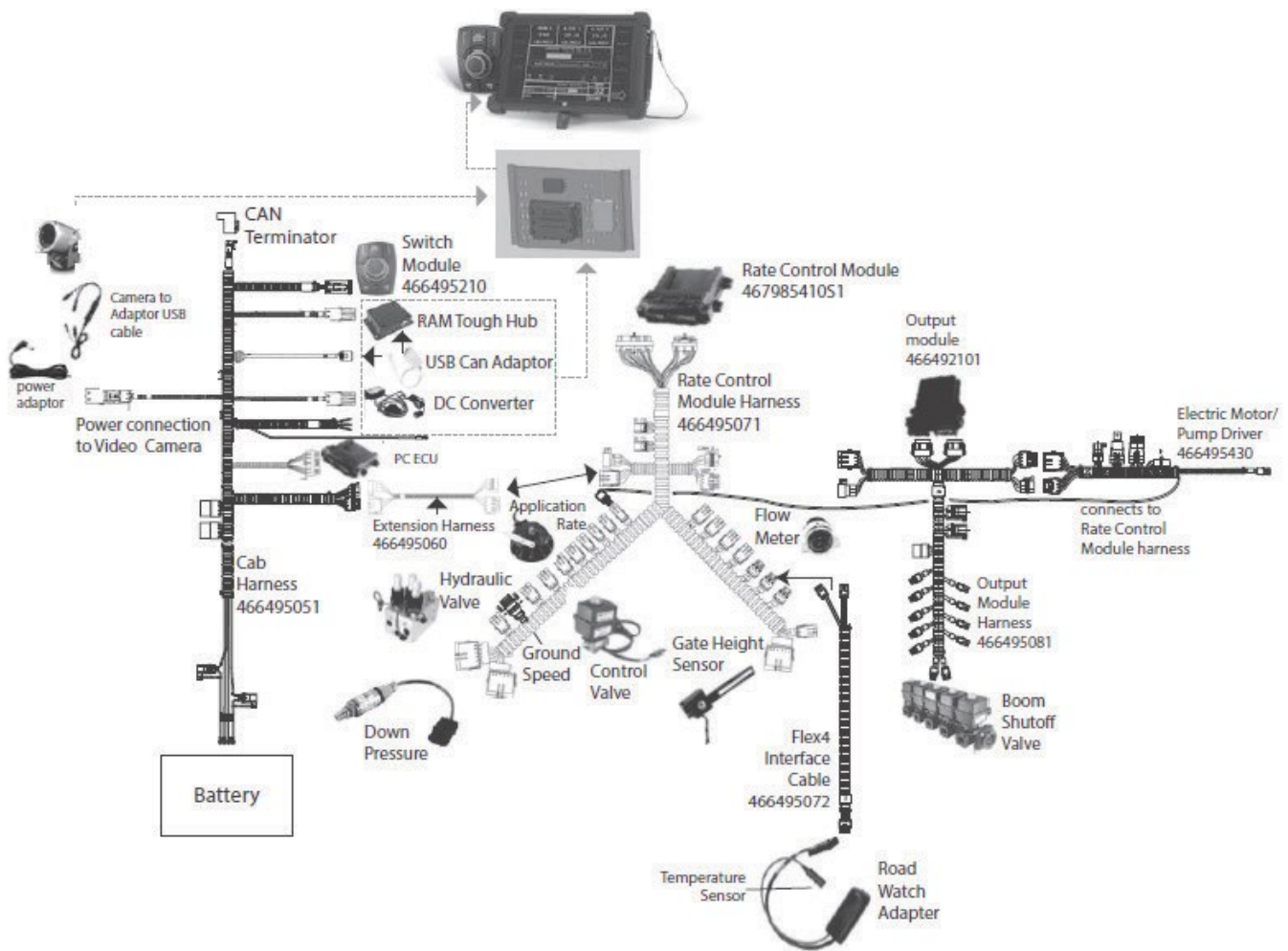

Cab Harness

Rate Control Harness

Output Module Harness

Flex4 Pro™

System Wiring Diagram

CONN 1 - BLACK

Pin	Function
6	F2 Fuse
7	Ground
2	Boom Output 1
3	CAN High
10	CAN Low
11	Boom Output 2
1	Gate Height
12	Gate Height
4	Plug NA
5	Plug NA
8	Plug NA
9	Plug NA

CONN H - GRAY

Pin	Function
8	F1 Fuse
5	F1 Fuse
7	Ground
6	Ground
11	Boom Output 6
10	Boom Output 5
2	Boom Output 4
3	Boom Output 3
1	Relay Socket 85
4	Conveyor Right
12	Conveyor Left
9	Auger Reverse

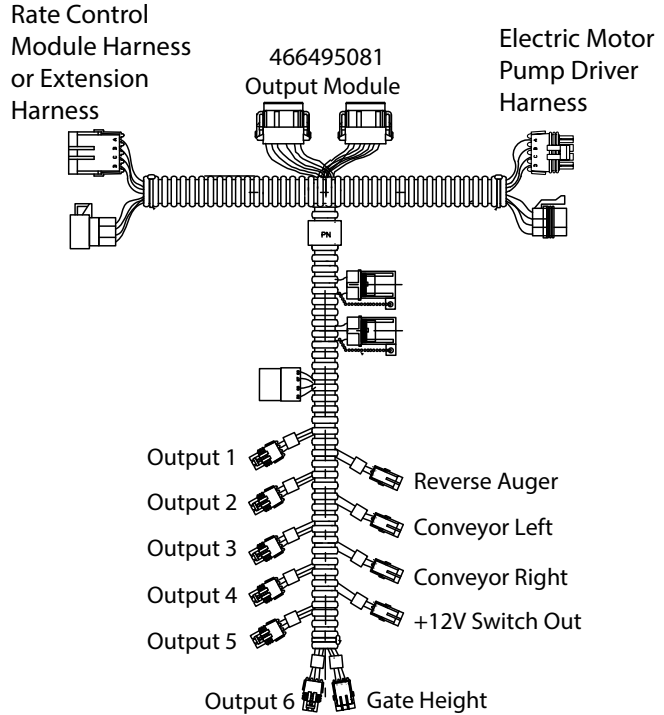

CONN A

Pin	Function
C3	Joystick Switch Input
H1	Servo Aux Open
G1	Servo Aux Close
F2	Servo Aux Aper
A1	Servo Liquid Open
C1	Servo Liquid Close
G3	Servo Liquid Aper
B3	Remote 12V Out
A3	Ground Speed
E1	Granular Feedback
E2	Aux Feedback
D3	Liquid Feedback
A2	Spinner Feedback
B1	Liquid PWM
J1	Aux PWM
D1	Granular PWM
K1	Spinner PWM
G2	Solenoid Ground
H3	Solenoid Ground
H2	Solenoid Ground
J3	Solenoid Power
K3	Solenoid Power
K2	Solenoid Power
F1	ECU Power
F3	ECU Ground
B2	CAN Low
C2	CAN High
E3	Plug NA
D2	Plug NA
J2	Plug NA

CONN B

Pin	Function
E3	Analog 2
C2	Analog 3
D2	Analog 4
B3	Analog 1
E1	Boom Sense 1
B2	Boom Sense 2
F1	Boom Sense 3
F2	Boom Sense 4
F3	Boom Sense 5
A2	Boom Sense 6
D1	Remote Blast
C1	Hopper Level
B1	Digital 2
A1	Digital 1
D3	Plug NA
C3	Plug NA
E2	Plug NA
A3	Plug NA

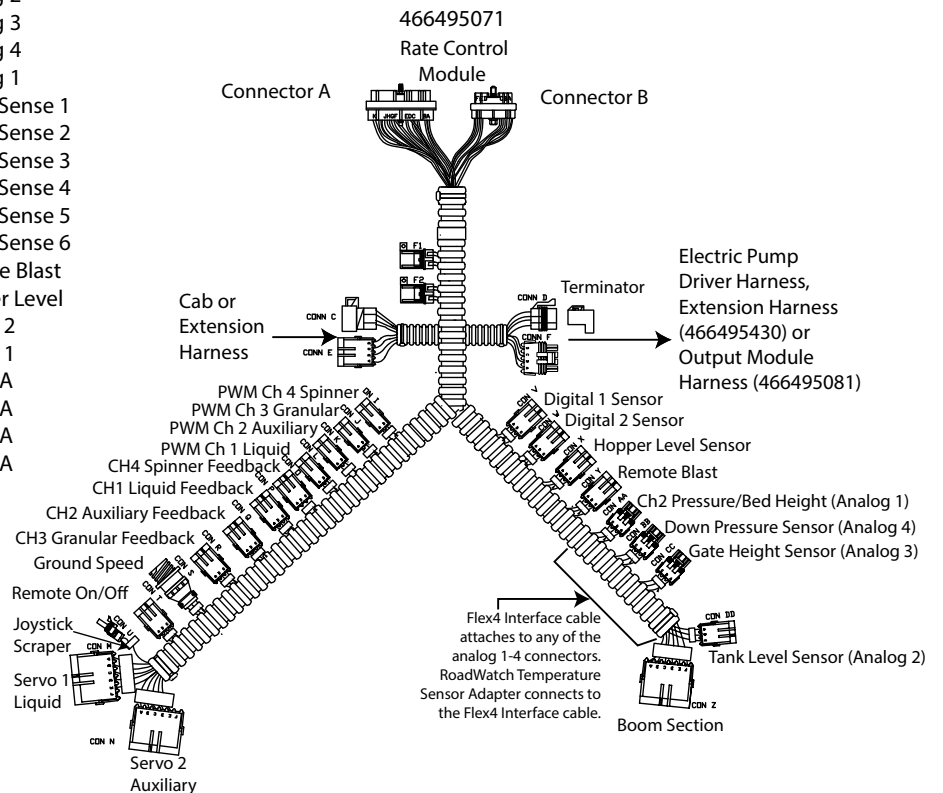

Flex4 Pro™



Flex4 Pro Terminal and Operator Remote Switch Module

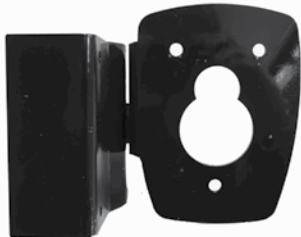

Optional Remote Switch Mounting Bracket



RAM Mount Kit



Cab/Power Harness



WSMT2 Rate Control Module Harness

Operator Interface and System Kit

The terminal and operator remote switch module are installed in the cab for control of material application.

Terminal features a 10.1" color display that provides simultaneous viewing of:

- Rates
- Spread width
- Vehicle speed
- Spread direction
- Road temperature
- Joystick selection
- Accessory input monitoring

Additional Features:

- Video camera connection
- USB RS232 port for data download and keyboard connection

Operator remote switch module consists of buttons that control material application rate and a spread width knob to adjust spinner speed and regulate spreading of material. The module is backlit for visibility during night operation.

The Flex4PROCOMBO kit includes the terminal, module, and required components for system operation. Additional components are available for added functionality.

FLEX4 Pro System	
Part Number	Description
FLEX4PROCOMBO	
Kit contains one each of the below components.	
700331051	Flex4 Pro Tablet Kit
700331151	Mounting Plate Hardware Kit
6010766	Cab Power Harness
46798506351	PCECU
6010784	USB Cable Tablet to USB Hub
6010794	USB Cable Tablet Charging
6010541	Flex4 Pro Operators Manual
464211700	Flex4 Pro Ground Speed Adapter Cable (required for use ONLY with certain electronic ground speed sensors)
466495210	Switch Module
46798541051	Rate Control Module
466495071	Rate Control Harness

Remote Switch Module Mounting Kit

An optional operator remote switch module mount (sold separately) mounts the switch module to the driver seat armrest.

Part Number	Description
466495130	Remote switch module mounting kit (Optional)

Flex4 Pro™

Cab Harness Add-Ons



Keyboard

Keyboard

A keyboard is required to program and calibrate the system. The keyboard has been environmentally hardened for use in the ice control field. After programming and calibration, the keyboard is disconnected and stored.

Part Number	Description
46649563051	Programming Keyboard



Camera



Adapter

Camera

A video camera installed on the rear of truck allows viewing of material dispensing and aids in backing the vehicle.



Extension Harness

Part Number	Description
466495600	Camera with 4.3mm Lens
466495610	Camera Adaptor
466495620	Camera Extension Harness 20'
6010765	Cable, Camera 12V Power Adapter
6010768	CBL, AGCAM Camera to USB Adapter



Extension Harness

Extension Harness

Extension harness (10 ft) is optional and used when extra length is required to connect with the Rate Control Module harness and/or the Output Module harness.

Part Number	Description
466495060	10" CAN Extension Harness



RoadWatch Temperature Sensor Adaptor

Temperature Sensor Adaptors

Current road and air temperature readings display on the Operate screen and triggers an audible alarm when outside of defined parameters.

Part Number	Description
466494100S1	Road Watch Temperature Sensor Adaptor
466492100S1	Surface Patrol Temperature Sensor Adaptor
466495072	Flex4 Pro Interface cable required with Temperature Sensor Adaptor

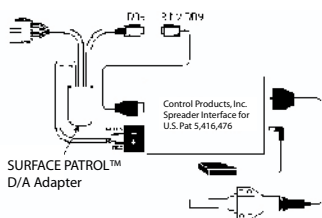

Surface Patrol Temperature Sensor Adaptor



Flex4 Pro Interface Cable

Flex4 Pro™

Cab Harness Add-Ons

Speed Sensors



Speed Sensor 464210507S1
 (additional sensors found at the
 Ground Speed Sensor section)

Speed sensor device reads the speed of vehicle wheel rotation.

Sensors	
Part Number	Description
464210507S1	El Speedo Navistar Sine Wave (*)
464210508S1	El Speedo Ford Sine Wave (*)
464210509S1	El Speedo w/MetriPack Connector Sine Wave (*)
464211450	El Speedo Navistar w/Deutsch Connectors Sine Wave (*)
464211440	El Speedo World Trans ECU V20 Socket Connector Sq Wave
463170192	El Speedo World Trans Wire 157 Sq Wave
463170191	El Speedo World Trans Wire 157 Sq Wave
466492130S1	El Speedo Navistar 5000/7000 12V VW Option
464211700	Adapter (Required with (*) marked part numbers above)

Ground Speed Sensor



Radar III

The ground speed sensor generates vehicle speed information for the console. Sensor electrical pulses proportional to the vehicle ground speed are vital to system operation because true vehicle ground speed is necessary for accurate product application.

Part Number	Description
467831000S9	Radar III with Mounting Hardware
467831000S1	Radar III only

Flex4 Ground Speed Adapter Cable

A Flex4 Ground Speed Adapter Cable is required with a Flex4 system when one of the following electronic ground speed adapters is utilized:



**Flex4 Ground Speed
 Adapter Cable**

- El Speedo Navistar Sine Wave p/n 464210507S1
- El Speedo Ford Sine Wave p/n 464210508S1
- El Speedo with Metri Pack Connectors Sine Wave p/n 464210509S1
- El Speedo Navistar with Deutsch Connector Sine Wave p/n 464211450

This cable attaches between the Rate Control Module harness ground speed connector and the electronic ground speed sensor.

Part Number	Description
464211700	Flex4 Ground Speed Adapter Cable (included in the FLEX4COMBO Kit) connects pin 4 of the sensors above to pin 2 of Flex4 ground speed connection

Flex4 Pro™

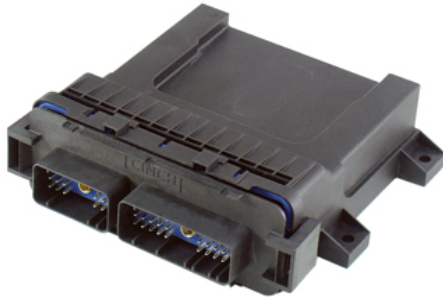

Rate Control Module

Rate Control Module and Add-Ons

The Rate Control Module houses the system's primary interface device. All system parameters, constants, and memory are stored in this module and controls the application of material by interfacing with proportional hydraulic valves and feedback sensors.

Extension harness (10ft) is optional and used when extra length is required to connect with the rate control module harness. Refer to cab harness page for diagram and part number.

Part Number	Description
467985410S1	Rate Control Module



Pre-Wet Flow Meter

Flow Meters

Used for flow rate measurement of material applied.

Pre-Wet

Part Number	Description
466491170S1	Flow Meter



Poly Flow Meter

Poly

Part Number	Description
PM00370023S1	3/4" Poly Flow Meter Assembly
PM00370030S1	1" Poly Flow Meter Assembly
PM00370040S1	1.5" Poly Flow Meter Assembly
PM00370048S1	2" Poly Flow Meter Assembly
PM00370048S2	2" Poly Flow Meter Assembly with 1.5" hose barbs
PM00370068S1	3" Poly Flow Meter Assembly
Flow Rate	
1/2"	0.79 - 7.90 GPM
3/4"	1.85 - 18.5 GPM
1"	2.64 - 26.4 GPM
1.5"	9.25 - 92.5 GPM
2"	19.0 - 198 GPM
3"	39.6 - 396 GPM

- 1/2" - 2" Poly Flow Meter assemblies include:
- Flow meter body with turbine, axle, and bearing
 - Hall-effect sensor with 3-pin Weather Pack connector
 - 2 hose barbs for inlet and outlet
 - 2 Viton o-rings
 - 2 coupling nuts



Adapter

Adapter

Part Number	Description
466490040S1	Raven Flow Meter Adapter

Flex4 Pro™

Rate Control Module Add-Ons



Gate Height Sensor

Gate Height Sensor

Measures gate height setting in inches and automatically adjusts conveyor speed to compensate for gate height changes and maintain application rate.

Part Number	Description
466492370S1	Gate Height Sensor



Down Pressure Sensor

Down Pressure Sensor

Hydraulic pressure sensors measure the amount of down pressure applied on the underbody scraper.

Part Number	Description
465700080S1	Down Pressure Hydraulic Sensor



Application Rate Sensor

Application Rate Sensor

Feedback sensors send product flow information to the console for accurate product application.

Part Number	Description
464360170S1	Application Rate Sensor 10' Cable WP
464360171S1	Application Rate Sensor 15' Cable WP
464360172S1	Application Rate Sensor 30' Cable WP
464360176S1	Application Rate Sensor 5' Cable WP
464360177S1	Application Rate Sensor 22' Cable WP
464360178S1	Application Rate Sensor 1' Cable WP
464211210S1	White Sensor Motor Adaptor



Reluctance Sensor

Reluctance Sensor

Part Number	Description
467881000S1	Reluctance Sensor



Extension Harness 15' 30', 45'

Application Rate Extension Harness

Part Number	Description
457901810	Extension Harness 15 ft.
457901811	Extension Harness 30 ft.
457901812	Extension Harness 45 ft.



Couplers

Application Rate Mounting Hardware

Part Number	Description
457141810	Mounting Hardware (includes 1" coupler)
457141850	Mounting Hardware (includes 1.25" coupler)

Flex4 Pro™

Output Module and Add-Ons



Output Module

The Output Module is an auxiliary to the Rate Control Module that drives additional accessories such as boom section shutoff valves, open and close V-Box gates, switching valves for front/rear conveyors, switching valves for left/right discharge cross conveyors, and accessory 12 volt switched output.

Part Number	Description
46798200151	Output Module

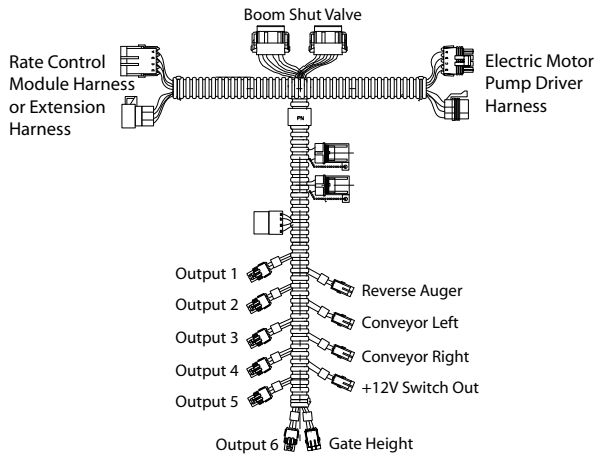

Output Module Harness

WSMB Output Harness

Output harness controls boom section shutoff.

Part Number	Description
466495081	Output Module Harness



**Extension Harness
466495060**

Extension Harness

Extension harness (10 ft) is optional and used when extra length is required to connect with the Rate Control Module harness and/or the Output Module harness.

Part Number	Description
466495060	10" CAN Extension Harness

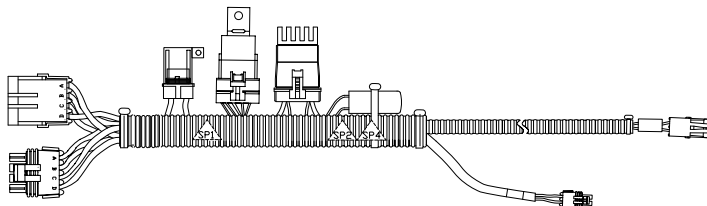

**Electric Motor Pump Harness
466495430**

Electric Motor Pump Harness

Used to drive electric pumps or motors that draw high current (greater than 2 amps).

Part Number	Description
466495430	Electric Motor Pump Harness
467980470	12 gauge 2 pin WP Extension Cable 15 ft.
467980471	12 gauge 2 pin WP Extension Cable 20 ft.
467980473	12 gauge 2 pin WP Extension Cable 30 ft.
467980472	12 gauge 2 pin WP Extension Cable 40 ft.

Flex4 Pro™

Parts Order List

To order a Flex4 Pro system, the following information is required to ensure the proper system is selected for the correct application. Any Flex4 Pro systems ordered require a calibration keyboard for entry of calibration and programming data. One keyboard, p/n 466490850S1, can be shared among multiple trucks.

FLEX4 PRO SYSTEM	PART NUMBER	DESCRIPTION	PART NUMBER	DESCRIPTION
<i>Flex4 Pro Base kit includes one each of parts included in the highlighted box.</i>	FLEX4PROCOMBO	Flex4 Pro System Base Kit		
	7003310	Flex4 Pro Tablet Kit	467985410S1	Rate Control Module
	7003311	Mounting Plate Hardware Kit	466495071	Rate Control Harness
	6010766	Cab Power Harness	464211700	Flex4 Pro Ground Speed Adapter Cable (required for use ONLY with certain electronic ground speed sensors)
	467985063S1	USB Cable Tablet to USB Hub		
	6010784	USB Cable Tablet Charging		
	6010541	Flex4 Pro Manual		
466495210	Switch Module			
ACCESSORIES				
	466495060	10' CAN Extension		
	466495081	WSMB Output Harness		
	466492101	WSMB Output Module		
	466495600	Camera 4.3mm Lens		
	466495610	Flex4 Camera Adapter		
	466495620	20' Camera Extension		
SPEED SENSORS (select 1)				
	464210507S1	El Speedo Navistar Sine Wave		
	464210508S1	El Speedo Ford Sine Wave		
	464210509S1	El Speedo w/Metri Pack Connectors Sine Wave		
	464211450	El Speedo Navistar w/Deutsch Connectors Sine Wave		
	464211440	El Speedo World Trans ECU V20 Socket Conn Sq Wave		
	463170192	El Speedo World Trans Wire 157 Sq Wave		
	463170191	El Speedo World Trans Wire 157 Sq Wave		
	466492130S1	El Speedo Navistar 5000/7000 12 VVW Option		
	467831000S9	Radar III with Mounting Hardware		
APPLICATION RATE SENSORS (select 1)				
	464360170S1	Application Rate Sensor 10' Cable		Which application rate sensor or adapter is required.
	464360171S1	Application Rate Sensor 15' Cable		
	464360172S1	Application Rate Sensor 30' Cable		
	464360176S1	Application Rate Sensor 5' Cable		
	464360177S1	Application Rate Sensor 22' Cable		
	464360178S1	Application Rate Sensor 1' Cable		
ARS/FLOW METER EXTENSION OPTIONS (select 1)				
	457901810	Extension Cable 15'		What is the correct cable length required for the flow meter and/or application rate sensor.
	457901811	Extension Cable 30'		
	457901812	Extension Cable 45'		
ARS MOUNTING HARDWARE (select 1)				
	457141810	Hardware GC1000-S 1" Coupler		
	457141850	Hardware GC1000-S 1.25" Coupler		
VALVE EXTENSION OPTION (select 1)				
	464211180	Dual PWM Valve Extension Harness 15'		Extension option for PWM Valve Driver 464210430S1.
HIGH CURRENT ELECTRIC MOTOR DRIVERS				
	466495430	Electric Motor/Pump Driver		
OPTIONS				
FLOW METERS				
	466491170S1	Pre Wet (0.3 - 5 GPM)		
	PM00370023S1	3/4" Poly (1.85 - 18.5 GPM)		
	PM00370030S1	1" Poly (2.64 - 26.4 GPM)		
	PM00370040S1	1.5" Poly (9.25 - 92.5 GPM)		
	PM00370048S1	2" Poly (19.0 - 198 GPM)		
	PM00370048S2	2" Poly w/1.5" Hose Barbs (19.0 - 198 GPM)		
	PM00370068S1	3" Poly (39.6 - 396 GPM)		
	466980040S1	Raven Flow Meter Adapter		
TEMPERATURE SENSOR ADAPTERS				
	466494100S1	Road Watch SS		
	466492100S1	Surface Patrol		
	466495072	Flex4 Interface Cable (required with RoadWatch)		
MISCELLANEOUS SENSORS				
	465700080S1	Down Pressure Hydraulic Sensor		
	466492370S1	Gate Height Sensor		
	6010768	Cable, Camera 12V Power Adapter		
	6010798	CBL, AGCAM Camera to USB Adapter		
	6010798	Converter, Mini - USB to RS-232		
GPS RECEIVER				
	69100-90	GPS Receiver Kit (Receiver, Cable Assy, Mounting Plate, Reference Guide)		

Flex4 Pro™

Parts Order List

Selecting System Components

FLEX4 SYSTEM	
PART NUMBER	DESCRIPTION
VALVES	
467092004S1	4 GPM Valve
467092008S1	8 GPM Valve
467092100	17/10 Hydraulic Valve
467092101	17/10 Hydraulic Valve Load Sense
467092110	34/10 Hydraulic Valve
467092111	34/10 Hydraulic Valve Load Sense
VALVE & ACTUATOR ASSEMBLIES	
467095010	Valve & Actuator Assembly 3/8" 2 way SS
467095020	Valve & Actuator Assembly 1/2" 2 way SS
467095030	Valve & Actuator Assembly 3/4" 2 way Poly
467095300	Valve & Actuator Assembly 3/4" 2 way SS
467095040	Valve & Actuator Assembly 1" 2 way CS
467095280	Valve & Actuator Assembly 1" 2 way Poly
467095290	Valve & Actuator Assembly 1" 2 way SS
467095050	Valve & Actuator Assembly 1.5" 3 way Poly
467095140	Valve & Actuator Assembly 1.5" 3 way SS
467095150	Valve & Actuator Assembly 2" 2 way SS
467095160	Valve & Actuator Assembly 2" 3 way SS
467095170	Valve & Actuator Assembly 3" 2 way SS
467095320	Valve & Actuator Assembly, 1/4" 2 way SS
LIQUID VALVE EXTENSION CABLES	
457901820	Liquid Valve Extension Cable 15'
457901821	Liquid Valve Extension Cable 30'
KEYBOARD	
466495630S1	Programming Keyboard with decal
466495630	Programming Keyboard only

LT Spreader Control

Features



The LT Spreader Control system has been designed to increase material spreading efficiency and allow for hydraulic spreader control valve installation outside of the cab.

When in the automatic mode, the LT Spreader Control varies the speed of the conveyor in proportion to ground speed to maintain a uniform application rate of material on the road. Spreading automatically starts when the vehicle begins to move and automatically stops when the vehicle stops.

The LT Spreader Control system consists of three components:

- Control console
- Ground speed sensor
- Valve

The console is installed in the cab and connected to the vehicle battery, hydraulic PWM spreader valve, and a ground speed sensor.

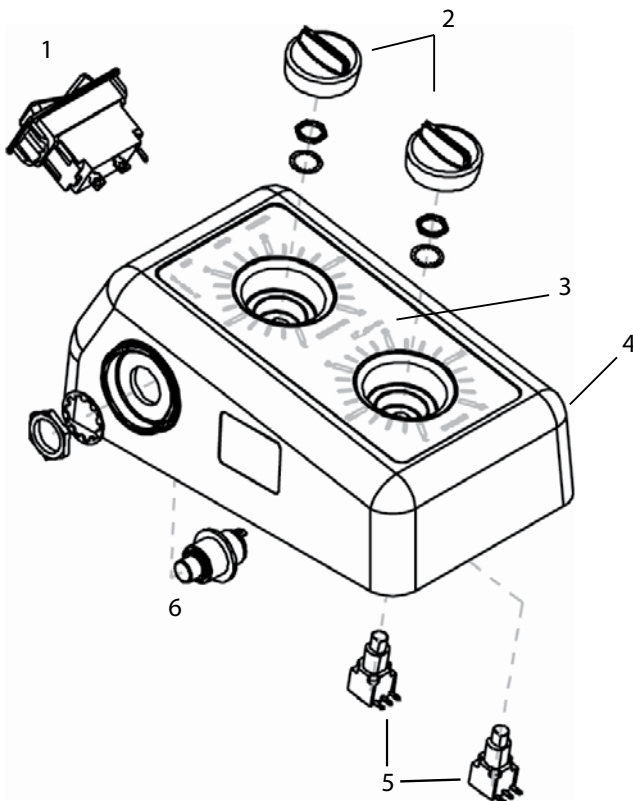

Part Number	Description
467660041S2	LT Spreader Control Console with Mounting Bracket
467660041S1	LT Spreader Control Console
466390910S1	Mounting Bracket

LT Spreader Control Parts

Item	Part Number	Description
1	212650040	Master Switch
2	466490320A	Conveyor/Spinner Knob
3	467660071	Decal
4	467660061	Housing
5	211590010	Potentiometer with Nuts
6	207380004	Blast Switch with Nut

Don't forget to select a:

- Speed sensor
- PWM valve

ICS2000

Features



Don't forget to select a:

- Ground Speed Sensor
- Hydraulic Valve
- Application Rate Sensor

ICS2000 systems include a console that must be programmed according to the system application.

Console programming varies depending on:

- Speed input type
- Hydraulic valve type
- Application rate sensor
- Units of measurement
- Language

The console program part number **MUST** be supplied when ordering an ICS2000 system to ensure the correct console is ordered for the system application.

ICS2000 Control Systems are used for various truck chassis, spreaders, and hydraulic systems. Kits can vary depending on length of cables required for application rate sensors, extension cables, speed sensors, and hydraulic valve type used. Some kits do not include an application rate sensor, ground speed sensor, or White Sensor Motor adapter cable.

The below table provides typical U.S. console programming part numbers. If other console programming numbers are required, call DICKEY-john® Sales and Service for assistance.

US Console Programming Part Numbers

Console Part Number	Speed Input	Valve Type	Application Rate Sensor	Unit of Measurement	Language
ICS0 0023A	Sine Wave	PWM	DICKEY-john®	Standard	English

NOTE:

Sine wave speed input is used with an electronic input signal. Square wave speed input is used with a World Transmission or mechanical speed input signal.

The White Motor sensor can replace a Dickey-john application rate sensor for ICS2000 consoles.

ICS2000

Wiring Diagram

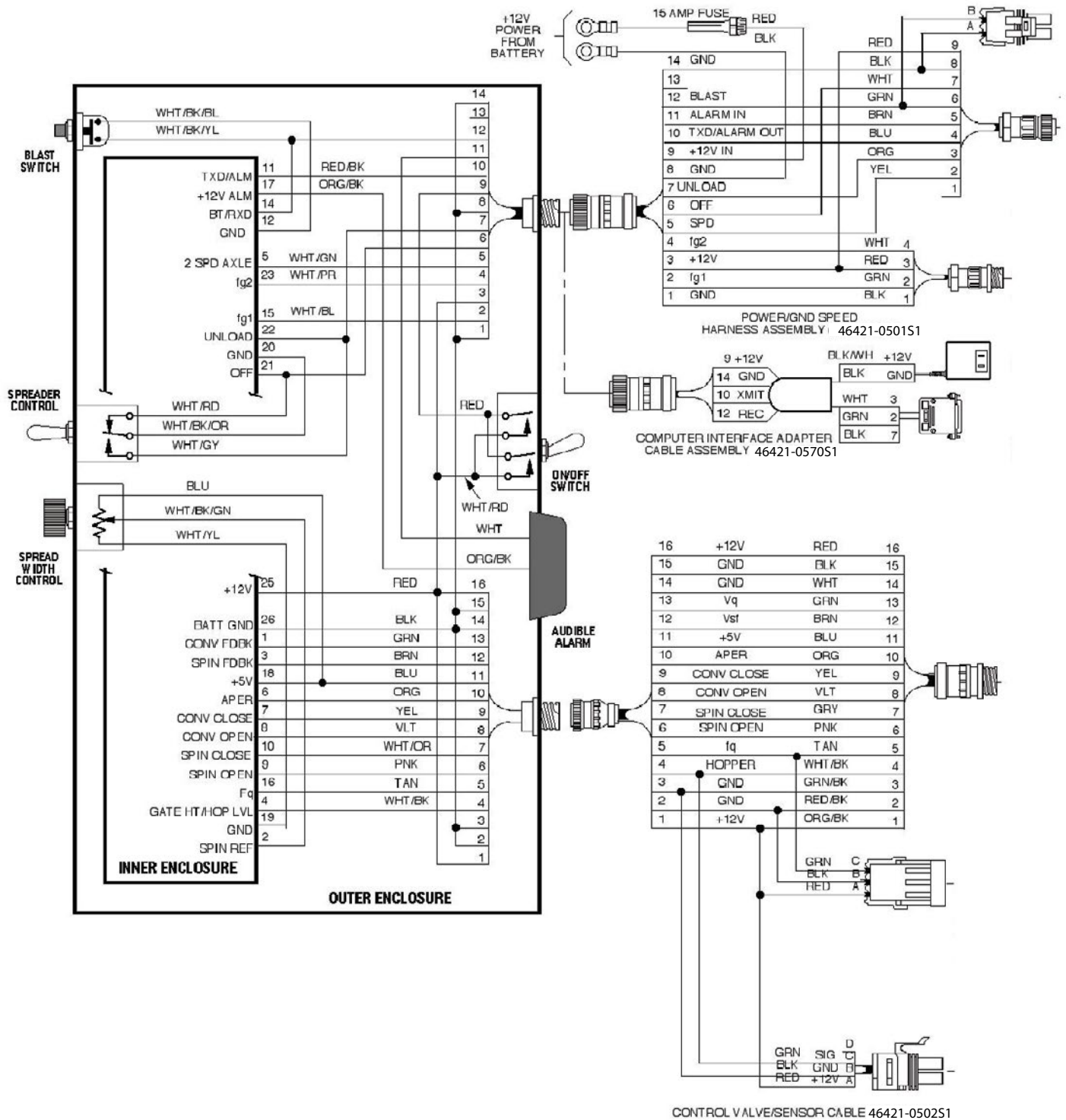

ICS2000

Wiring Diagram

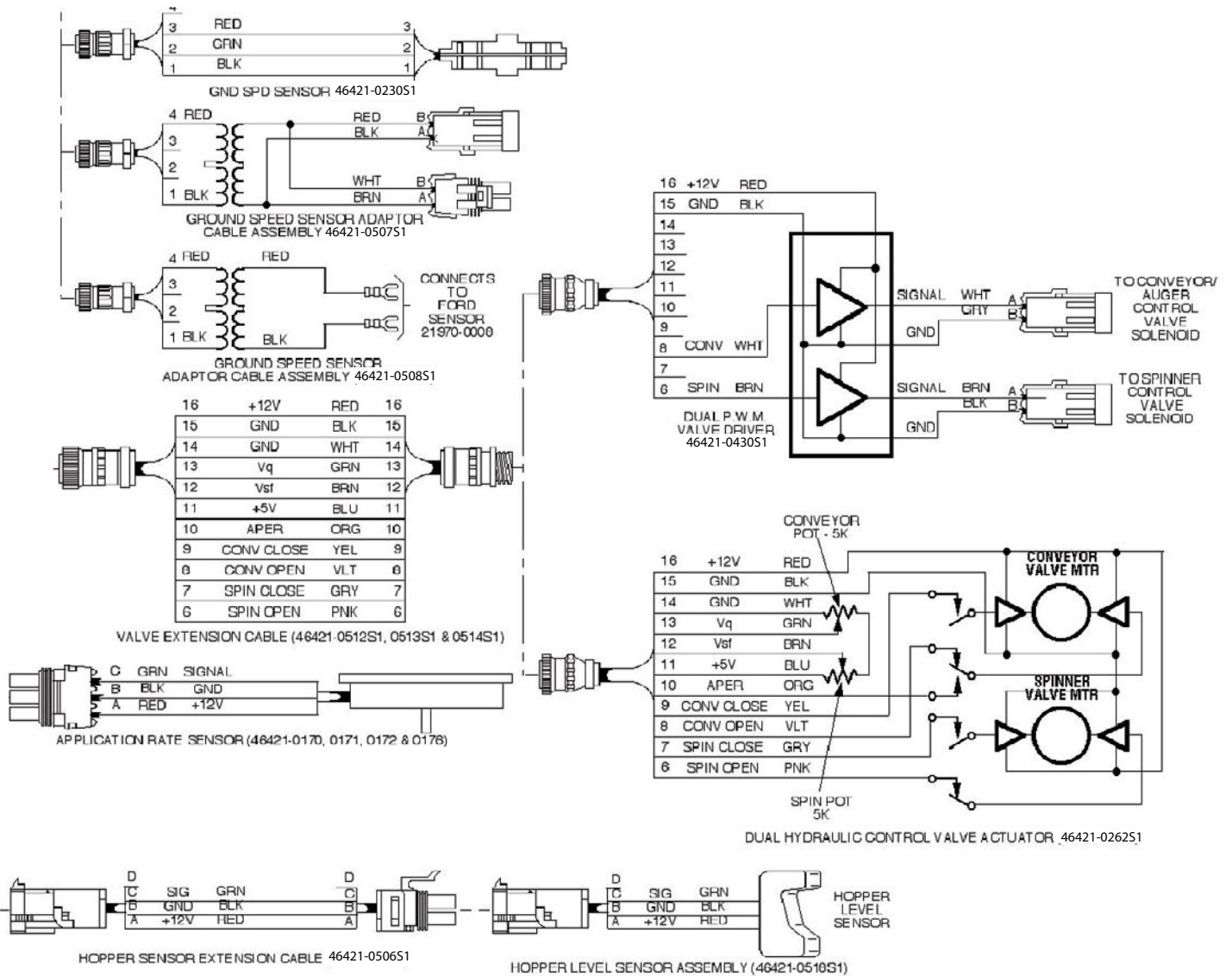
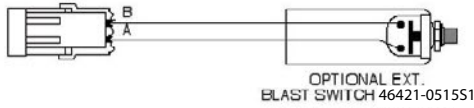

ICS2000

Parts Order List (with ARS Kit)

Selecting System Components

ICS2000 w/ARS		
PART NUMBER	DESCRIPTION	
ICS2000 W ARS BASE KIT		
464210501S1	Harness Power/Ground Speed	ICS2000 Consoles ordered must match number of ICS2000 System Base Kits ordered.
464210502S1	Cable VLV/Sensor ICS2000	
464210860S1	BDL Hardware ICS2000	
110010950	Operator's Manual	
110010958	Calibration & Programming Manual	
ICS2000 CONSOLE		
ICS00023A	ICS2000 Console	Console required with each system.
SENSORS		
SPEED SENSORS (select 1)		
464210507S1	El Speedo Navistar Sine Wave	
464210508S1	El Speedo Ford Sine Wave	
464210509S1	El Speedo w/Metri Pack Connectors Sine Wave	
464211450	El Speedo Navistar w/Deutsch Connectors Sine Wave	
464211440	El Speedo World Trans ECU V20 Socket Conn Sq Wave	
463170192	El Speedo World Trans Wire 157 Sq Wave	
463170191	El Speedo World Trans Wire 157 Sq Wave	
466492130S1	El Speedo Navistar 5000/7000 12V VW Option	
APPLICATION RATE SENSORS (select 1)		
464360170S1	Application Rate Sensor 10' Cable	Which application rate sensor or adapter is required.
464360171S1	Application Rate Sensor 15' Cable	
464360172S1	Application Rate Sensor 30' Cable	
464360176S1	Application Rate Sensor 5' Cable	
464360177S1	Application Rate Sensor 22' Cable	
464360178S1	Application Rate Sensor 1' Cable	
ARS MOUNTING HARDWARE		
457141810	Hardware GC1000-S 1" Coupler	
457141850	Hardware GC1000-S 1.25" Coupler	
ARS/FLOW METER EXTENSION OPTIONS		
457901810	Extension Cable 15'	
457901811	Extension Cable 30'	
457901812	Extension Cable 45'	
PWM VALVE DRIVERS		
464210430S1	Driver Valve ISC2000	Choose a valve driver when using a proportional hydraulic spreader control valve or a drop on actuator when using a 2FFL12 Series hydraulic valve.
VALVE EXTENSION OPTION		
464210512S1	10' Valve Sensor Cable Extension	Extension option for PWM Valve Driver 464210430S1
464210513S1	20' Valve Sensor Cable Extension	
464210514S1	30' Valve Sensor Cable Extension	
464211180	15' Dual PWM Valve Extension Harness	

Control Point®

Control Systems

Console Parts



Item	Part Number	Description
1	466490650	Decal, DICKEY-john® logo
2	466490660	Decal, Control Point®
3	207380006	On/Off Pushbutton Switch
4	207380010	On/Off Button, Black

Console Mounting Hardware

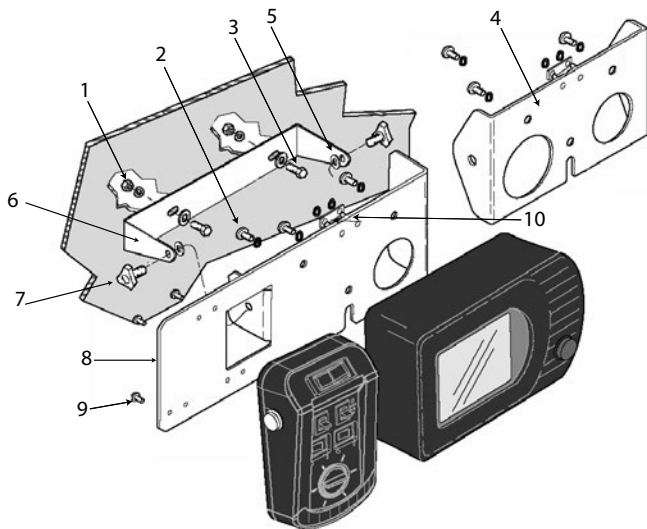

Item	Part Number	Description
1	46649038151	Console/Switch Module Mounting Hardware
2	200400011	1/4" - 20 Hex Nut (2)
3	200140005	1/4"-20 x 1" Hex Bolt (3)
4	200140027	1/4 - 20 x 1" Hex Bolt (2)
5	466390900	Washer, Rubber
6	466490590	U Bracket
7	200720022	Knob, Screw (2)
8	466490580	Combination Mounting Plate
9	213890017	#6 x 1/2" Screw (3)
10	466490350	Retaining Clip

Mounting hardware to secure the mounting bracket to the dash/mounting panel is not supplied with the kit.

Switch Module

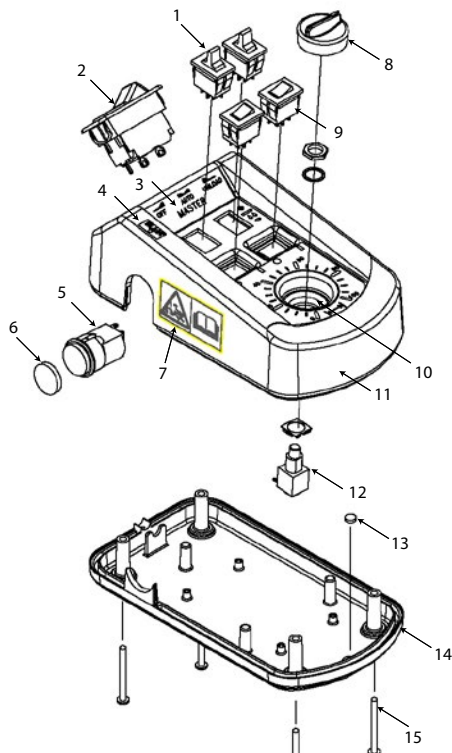

Item	Part Number	Description
	46649330051	Standard Switch Module
	46649320051	Wireless Switch Module
1	212650010	Rocker Switch SPDT (2)
2	212650039	Master Rocker Switch
3	466490680	Decal, Master Switch
4	466490670	Decal, Blast
5	207380011	Blast Push Button Switch
6	207380009	Button, Red
7	466491300	Decal, Warning
8	466490320A	Knob, Spread Width
8A	46649032151	Service Knob, Spread Width (2 piece)
9	212650011	Rocker Switch SPST (2)
10	466490690	Decal Spread Width Adjust
11	466490300	Switch Module Cover
12	211590010	Potentiometer
13	445010002	Disc
14	466490400	Switch Module Base
15	213890054	Screw (4)

Switch module items 1-15 are the same for the Standard and Wireless Switch Modules.

Joystick

Multi-Function

Multi-Function Joysticks control all hydraulic plow functions in one system when the truck ignition key is enabled. The joystick provides multi-axis proportional control for up to four independent hydraulic functions:

- front plow
- dump body
- wing
- scraper

A retractable joystick can be secured underneath the armrest maximizing operator comfort when not in use.

The joystick is equipped with a safety trigger to initiate movement of the hydraulic function to ensure operation activates when the operator is ready.

An emergency wing extract button on side of armrest automatically moves the wing plow into home position to avoid oncoming obstacles.

An optional float harness is available for hydraulic systems with float functionality.

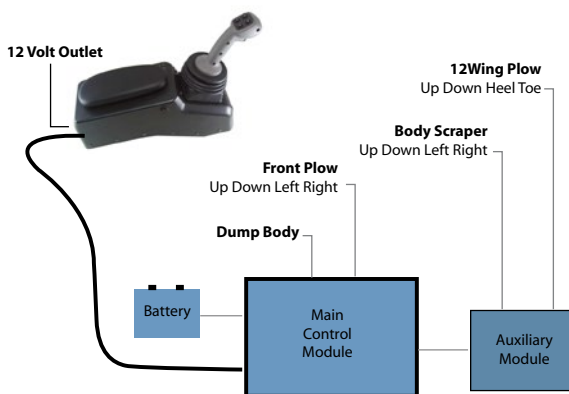
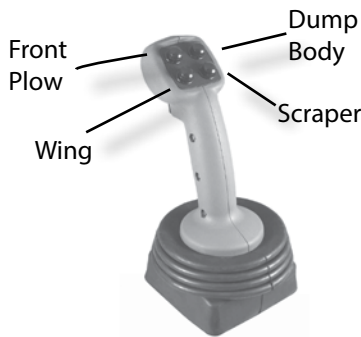

FEATURES:

- Multi-axis
- Retractable joystick
- Joystick grip with safety trigger to initiate movement of hydraulic function
- Auto wing retract
- Armrest assembly attaches to driver seat maximizing cab space
- Adjustable armrest for operator comfort
- LED indication for function selection
- 12V convenience plug for accessories

APPLICATIONS:

- Snow Plows
- Tractor Backhoes
- Bucket Trucks
- Garbage Trucks
- Any hydraulic control application

Joystick

Multi-Function

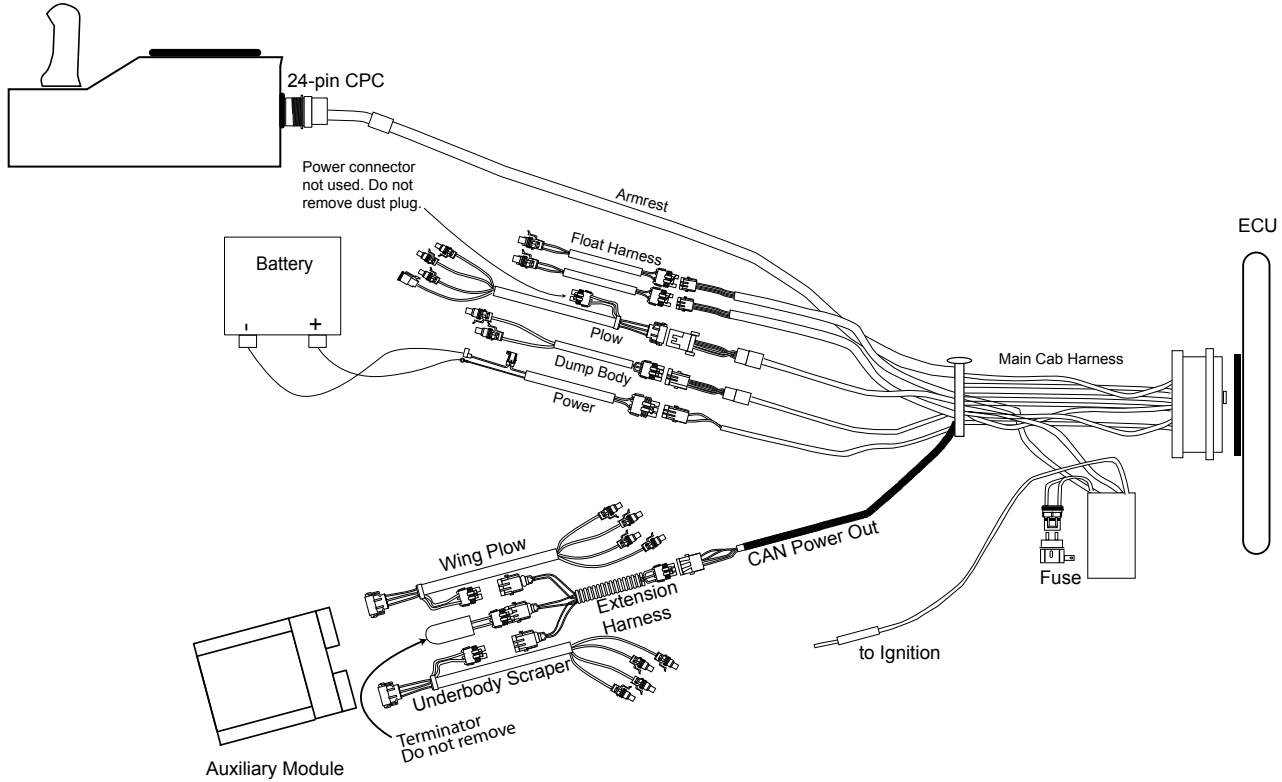

Multi-Function Basic (Front Plow and Hoist Control)

Multi-Function Plus Joystick (Front Plow, Hoist, Scraper, Wing Control)

Part Number	Description
467960520	HydraForce Multi-Function Joystick Armrest Assembly
467960600	Joystick Bracket Seat Assembly
467960710	ECU-MS Controller
467960420	Power Harness
467960470	Cab Interface Harness
467960440	Plow Harness
467960450	Dump Body Harness
467960510	4 LED Array

Part Number	Description
467960520	HydraForce Multi-Function Joystick Armrest Assembly
467970600	Joystick Bracket Seat Assembly
467960710	ECU-MS Controller
467960420	Power Harness
467960470	Cab Interface Harness
467960440	Plow Harness
467960450	Dump Body Harness
467960480	Body Scraper Harness
467960430	CAN Power Harness
467960740	Auxiliary Module

Deutsch 2 pin Connectors

Part Number	Description
219590022	Plug (harness side)
219600001	Socket contact (used with plug)
219590024	Receptacle (valve side)
219600002	Pin contact (used with receptacle)
219590023	Wedge

Service Parts

Part Number	Description
467960460	Float Harness
467960400	CAN Terminator
467960700	Joystick only
467960730	Connector 70 pin

Hydraulic Valves

PVC3000

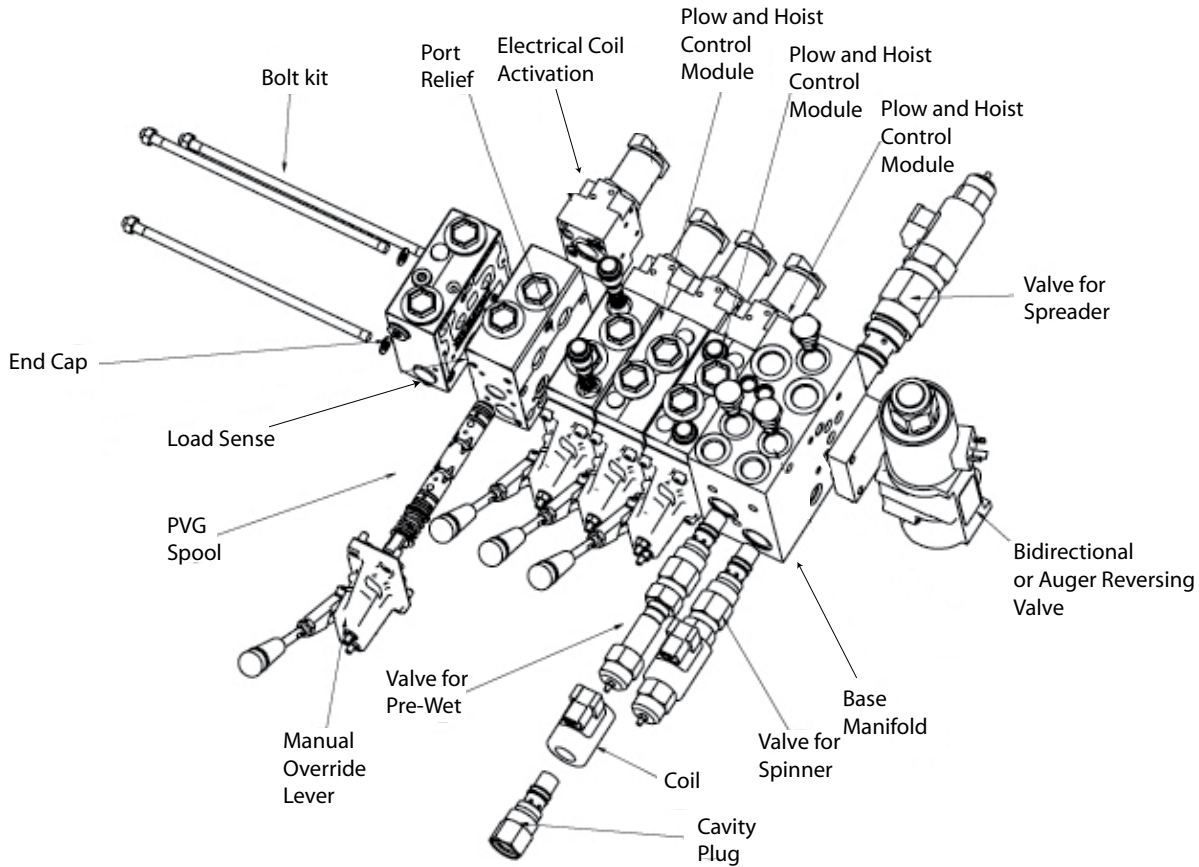

Mechanical Lever and Electrical Coils

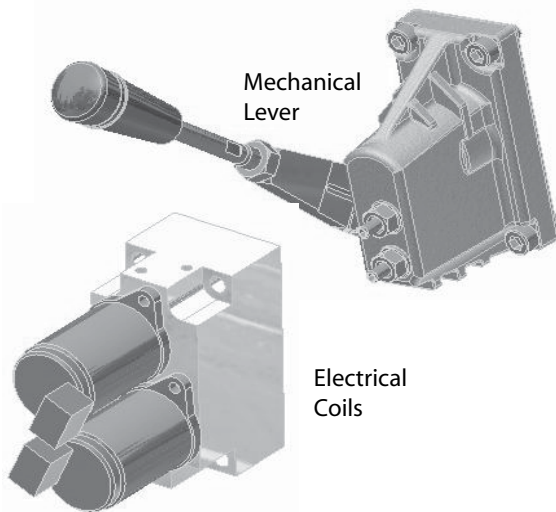

Part Number	Description
467094000	Mechanical Lever
467094005	Mechanical Lever Seals
467094010	Electrical Activation for Section (coils)
467094015	Electrical Activation Seals

Hydraulic Valves

PVC3000



Conveyor, Spinner, Pre-Wet Proportional Valves

Part Number	Description
467094065	Proportional Valve for Conveyor
467094070	Proportional Valve for Spinner
467094075	Proportional Valve for Pre-Wet
467094080	Cavity Plug for Valve without Pre-Wet Option
467094085	Coil for any Proportional Valve

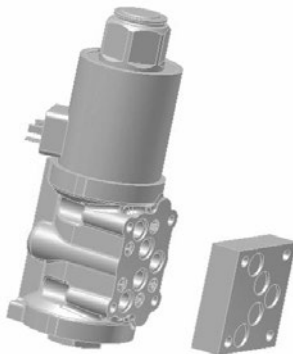

Bi-Directional Valve for Conveyor

Part Number	Description
467094090	Directional Valve
467094095	Mounting Bolts Set
467094100	Directional Valve Coils
467094105	Seals
467094110	Cover (if bi-directional valve is not used)



Check Valve for Base Manifold

Part Number	Description
467094115	Check Valve

Ground Speed Control



Speed-O-Meter Adapter

GC15/31/47 Series controls only.

Part Number	Description
46317-0020S1	Electronic Speed-O-Meter Adapter (Dixson Head)
46317-0031S1	Electronic Speed-O-Meter Adapter (Navistar/GMC/Volvo)

Limited service parts are available for the Granular Spreader Control (GC) and Automated Servo Control (ASC). Locate the product part number on the end of the console to order replacement parts. **All orders accepted for the Granular Spreader Control and Automated Servo Control are final. No returns or cancellations are accepted.**

Accessories

Pressure Sensor - Liquid



Liquid Pressure Sensor

Part Number	Description
465700010	Pressure Sensor (0 - 100 psi)
465700020	Pressure Sensor (0 - 650 psi)
465700040	Pressure Sensor (0 - 225 psi)

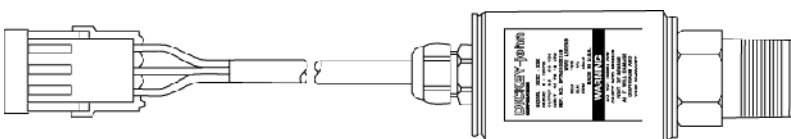

Connector Pin Outs		
Pin	Color	Function
A	Red	+12V
B	Black	Ground
C	Green	Signal (0-5)

Hydraulic Servo

Single Flow



Use with Hydraulic Valve Driver
Module 46436-0030A

Use with Hydraulic Valve Driver
Module 46436-0030A

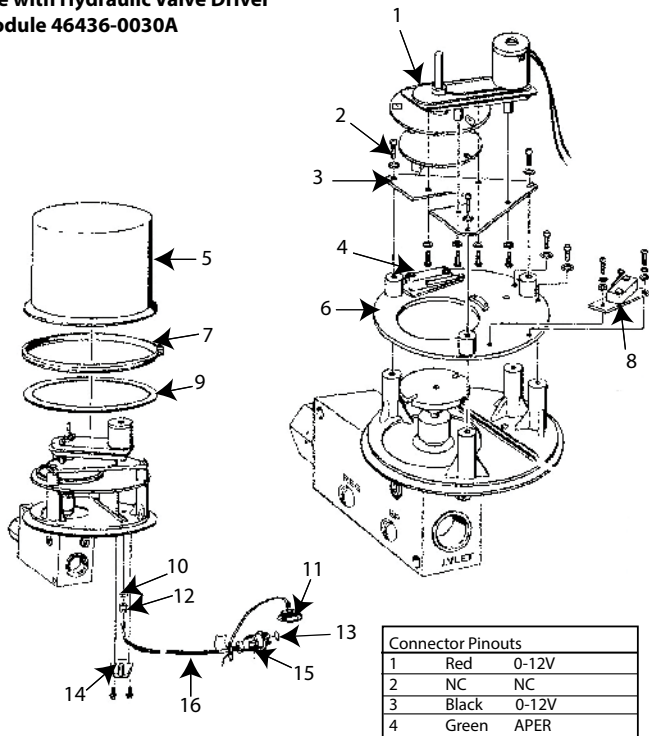

Connector Pinouts		
1	Red	0-12V
2	NC	NC
3	Black	0-12V
4	Green	APER

ITEM	Part Number	Description
1	44506-0001	Motor and Coupling
2	45714-0170	Center Coupling
3	45714-0180	Mounting Plate
4	45675-4023	Switch Assembly (black)
5	42282-0002	Valve Cover
6	45714-0120	Center Plate
7	21034-0002	Clamp
8	45675-4022	Switch Assembly (red)
9	42148-0004	Seal
10	21028-0023	O-ring
11	42147-0001	Dust Cover
12	44313-0001	Retainer
13	21093-0001	Seal Ring
14	44316-0001	Clamp
15	11059-0008	Connector Kit
16	43940-0021	Cable complete 10 ft.
	43940-0022	Cable complete 20 ft.
	43940-0023	Cable complete 30 ft.

Complete motor/actuator assembly for hydraulic servo valve use replacement parts:

- 46709-5360 Actuator only
- 46709-8040 Hardware Mounting Kit

The system must be in operation to make adjustments. Both adjustments are located under the center plate.

CAUTION: Be cautious to not overspeed the hydraulic motor.
Adjustment 1 (To eliminate creep)

1. Loosen the Allen head screw (large) in the coupling collar.
2. Using pliers, rotate the valve stem until creep stops to establish a closed position.
3. Retighten the collar.

Adjustment 2 (Adjust maximum flow rate gpm)

1. Loosen the small Allen head screw in the orifice adjustment collar.
2. Using pliers, turn the orifice adjustment collar counterclockwise to increase flow; clockwise to decrease flow.
3. Retighten orifice collar screw.

ICS2000

Console Parts

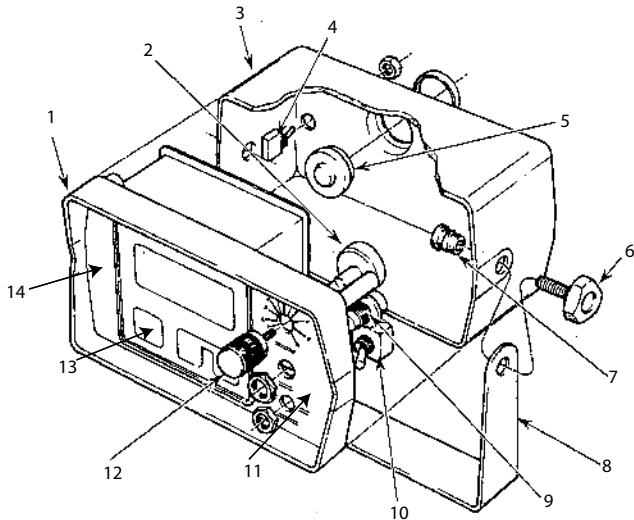

Item	Part Number	Description
	46421001051	ICS2000 Console (must be programmed)
1	464210270	Front Panel
2	209110001	Spread Width Control Pot
3	464210280	Rear Enclosure
4	215280009	On/Off Switch with Nut and Washer
5	201090004	Sonalert
6	200720022	Mounting Knob
7	20137	Well Nut
8	403440041	Mounting Bracket
9	207380004	Blast Push Button
10	210470003	Spreader Control Switch with Nut
11	464210310	Decal, Spread Width/Spreader Control
12	200720025	Spread Width Knob with Set Screws
13	464210320	Panel Graphcs ICS2000
14	424210670	Decal, Trim
15	210270003	Lamp GE#73 (not pictured)

Connectors & Kits



Part Number	Description
11059-0007	4 Pin w/Locking Ring Kit
21090-0001	Plug Body
21090-0004	Connector Body
21088-0001	Socket Contact (20-24 ga.)
21088-0002	Socket Contact (14-18 ga.)
21089-0001	Pin Contact (20-24 ga.)
21089-0002	Pin Contact (14-18 ga.)
21092-0001	Clamp

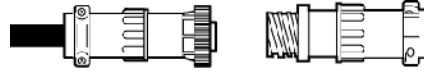

Part Number	Description
11059-0008	4 Pin without Locking Ring Kit
21091-0001	Connector Body
21091-0003	Connector Body
21088-0001	Socket Contact (20-24 ga.)
21088-0002	Socket Contact (14-18 ga.)
21089-0001	Pin Contact (20-24 ga.)
21089-0002	Pin Contact (14-18 ga.)
21092-0001	Clamp

Part Number	Description
11059-0009	9 Pin with Locking Ring Kit
21090-0006	Connector Body
21088-0001	Socket Contact (20-24 ga.)
21088-0002	Socket Contact (14-18 ga.)
21092-0004	Clamp

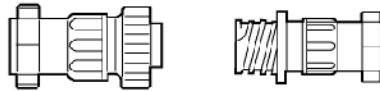

Part Number	Description
11059-0010	6 Pin without Locking Ring Kit
21091-0006	Connector Body
21089-0001	Pin Contact (20-24 ga.)
21089-0002	Pin Contact (14-18 ga.)
21092-0004	Clamp

Part Number	Description
11059-0011	14 Pin with Locking Ring Kit
21090-0003	Connector Body
21088-0001	Socket Contact (20-24 ga.)
21088-0002	Socket Contact (14-18 ga.)
21092-0007	Clamp



Part Number	Description
11059-0012	14 Pin without Locking Ring Kit
21091-0004	Connector Body
21089-0001	Pin Contact (20-24 ga.)
21089-0002	Pin Contact (14-18 ga.)
21092-0007	Clamp

Part Number	Description
11059-0013	16 Pin with Locking Ring Kit
21090-0002	Connector Body
21088-0001	Socket Contact (20-24 ga.)
21088-0002	Socket Contact (14-18 ga.)
21092-0007	Clamp



Part Number	Description
11059-0014	16 Pin without Locking Ring Kit
21091-0002	Connector Body
21089-0001	Pin Contact (20-24 ga.)
21089-0002	Pin Contact (14-18 ga.)
21092-0007	Clamp

Part Number	Description
11059-0005	37 Pin with Locking Ring Kit
21090-0005	Connector Body
21088-0001	Socket Contact (20-24 ga.)
21088-0002	Socket Contact (14-18 ga.)
21092-0003	Clamp

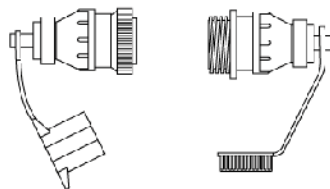

Part Number	Description
11059-0016	37 Pin without Locking Ring Kit
21101-0005	Connector Body
21089-0001	Pin Contact (20-24 ga.)
21089-0002	Pin Contact (14-18 ga.)
21092-0003	Clamp

Connectors & Kits

Weather Pack

Socket contacts, pin contacts, and seals are the same part numbers for all Weather Pack plugs and receptacles. Weather Pack connector kits and accessories page 59.

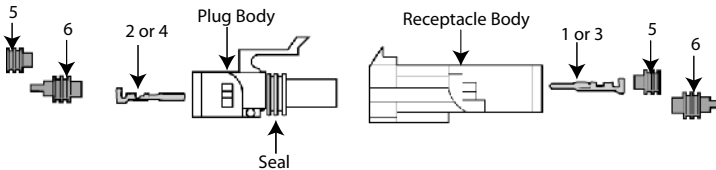

Item	Part Number	Description
1	21896-0001	Pin Contact 18-20 ga.
2	21896-0002	Socket Contact 18-20 ga.
3	21896-0003	Pin Contact 14-16 ga.
4	21896-0004	Socket Contact 14-16 ga.
5	21897-0001	Seal (hole through center) (sealed around wire)
6	21897-0002	Seal (solid center) (seals unused hole)

AMP

Socket contacts and pin contacts are the same part numbers for all AMP CPC plugs and receptacles. AMP connector kits and accessories page 64.

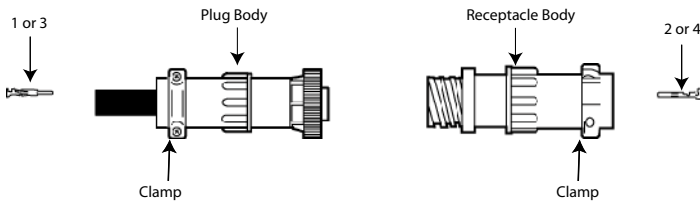

Item	Part Number	Description
1	21089-0001	Pin Contact (20-24 ga.)
2	21088-0001	Socket Contact (20-24 ga.)
3	21089-0002	Pin Contact (14-18 ga.)
4	21088-0002	Socket Contact (14-18 ga.)

ITT Cannon

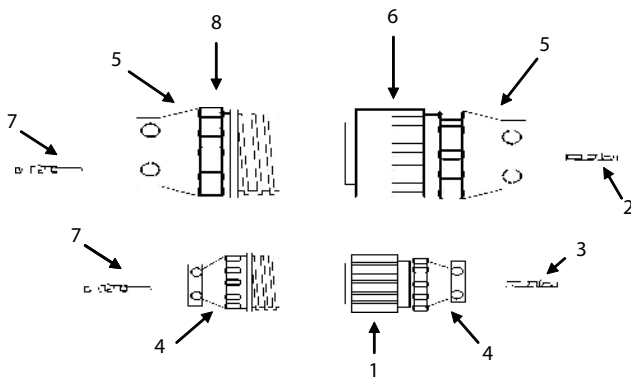

Item	Part Number	Description
ITT Cannon Kit 23-pin		
1	22048-2001	Connector Receptacle Body
2	22048-5002	Socket Contact (16-20 ga.)
3	22048-5003	Socket Contact (20-22 ga.)
4	22048-9003	Strain Relief
5	22048-9001	Strain Relief
6	22048-4002	Receptacle Body 48-pin
7	22048-5007	Pin Contact
8	220483003	Connector 48-pin

Deutsch

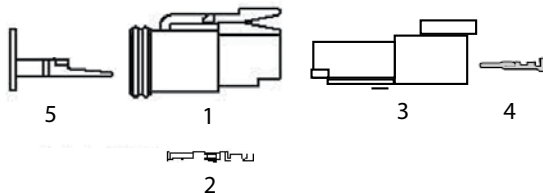

Item	Part Number	Description
1	21959-0022	Plug (harness side)
2	21960-0001	Socket Contact (used with plug)
3	21959-0024	Receptacle (valve side)
4	21960-0002	Pin Contact (used with receptacle)
5	21959-0023	Wedge

Fuse

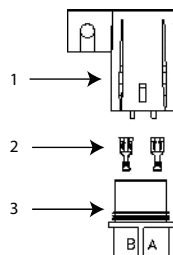

Fuse/AMP

Item	Part Number	Description
	20112-0046	Fuse 5 Amp
1	21895-0007	Fuse Cap
2	21896-0005	Fuse Sockets
3	21894-0007	Fuse Body

Connectors & Kits

Part Number	Description
46682-0770S1	1 Pin Connector Kit
21894-0001	Plug Body (male)
21896-0002	Socket Contact (18-20 ga.)
21896-0004	Socket Contact (14-16 ga.)
21897-0001	Seal, hole (18-20 ga.)
21897-0002	Seal, hole (14-16 ga.)



Part Number	Description
46627-0250	2 Pin Connector Kit
21894-0002	Plug Body (male)
21896-0002	Socket Contact (18-20 ga.)
21896-0004	Socket Contact (14-16 ga.)
21897-0001	Seal, hole (18-20 ga.)
21897-0002	Seal, hole (14-16 ga.)

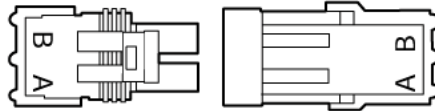

Part Number	Description
46627-0270	3 Pin Connector Kit
21894-0003	Plug Body (male)
21896-0002	Socket Contact (18-20 ga.)
21896-0004	Socket Contact (14-16 ga.)
21897-0001	Seal, hole (18-20 ga.)
21897-0002	Seal, hole (14-16 ga.)

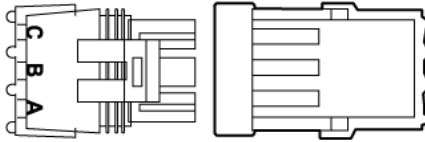

Part Number	Description
46627-0710	4 Pin Connect Kit, Flat
21894-0004	Plug Body (male)
21896-0002	Socket Contact (18-20 ga.)
21896-0004	Socket Contact (14-16 ga.)
21897-0001	Seal, hole (18-20 ga.)
21897-0002	Seal, hole (14-16 ga.)

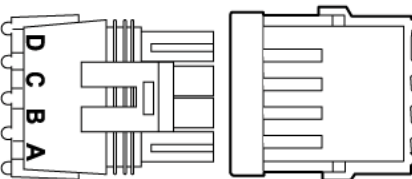

Part Number	Description
46627-0290	4 Pin Connector Kit, Square
21894-0005	Plug Body (male)
21896-0002	Socket Contact (18-20 ga.)
21896-0004	Socket Contact (14-16 ga.)
21897-0001	Seal, hole (18-20 ga.)
21897-0002	Seal, hole (14-16 ga.)

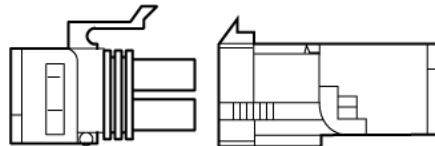

Part Number	Description
46627-0730	6 Pin Connector Kit, Slat
21894-0006	Plug Body (male)
21896-0002	Socket Contact (18-20 ga.)
21896-0004	Socket Contact (14-16 ga.)
21897-0001	Seal, hole (18-20 ga.)
21897-0002	Seal, hole (14-16 ga.)

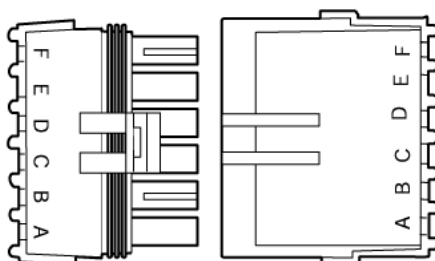

Weather Pack

Part Number	Description
46682-0770S1	1 Pin Receptacle Kit
21895-0001	Receptacle Body (female)
21896-0001	Pin Contact (18-20 ga.)
21896-0003	Pin Contact (14-16 ga.)
21897-0001	Seal, hole (18-20 ga.)
21897-0002	Seal, hole (14-16 ga.)

Part Number	Description
46627-0240	2 Pin Receptacle Kit
21895-0002	Receptacle Body (female)
21896-0001	Pin Contact (18-20 ga.)
21896-0003	Pin Contact (14-16 ga.)
21897-0001	Seal, hole (18-20 ga.)
21897-0002	Seal, hole (14-16 ga.)

Part Number	Description
46627-0260	3 Pin Receptacle Kit
21895-0003	Receptacle Body (female)
21896-0001	Pin Contact (18-20 ga.)
21896-0003	Pin Contact (14-16 ga.)
21897-0001	Seal, hole (18-20 ga.)
21897-0002	Seal, hole (14-16 ga.)

Part Number	Description
46627-0720	4 Pin Receptacle Kit, Flat
21895-0004	Receptacle Body (female)
21896-0001	Pin Contact (18-20 ga.)
21896-0003	Pin Contact (14-16 ga.)
21897-0001	Seal, hole (18-20 ga.)
21897-0002	Seal, hole (14-16 ga.)

Part Number	Description
46627-0280	4 Pin Receptacle Kit, Square
21895-0005	Receptacle Body (female)
21896-0001	Pin Contact (18-20 ga.)
21896-0003	Pin Contact (14-16 ga.)
21897-0001	Seal, hole (18-20 ga.)
21897-0002	Seal, hole (14-16 ga.)

Part Number	Description
46627-0740	6 Pin Receptacle Kit, Flat
21895-0006	Receptacle Body (female)
21896-0001	Pin Contact (18-20 ga.)
21896-0003	Pin Contact (14-16 ga.)
21897-0001	Seal, hole (18-20 ga.)
21897-0002	Seal, hole (14-16 ga.)

Specifications subject to change without notice.

DICKY-john®
5200 Dickey John Road
Auburn, IL 62615 USA
Toll Free: +1-800-637-3302
Phone: +1 217-438-3371
www.dickey-john.com



5200 Dickey John Road
Auburn, IL 62615
www.dickey-john.com

+1 217-438-3371
+1 217-438-6012 fax
©2023 DICKY-john

DICKY-john and the DICKY-john Logo are registered trademarks of TSI Incorporated in the United States and may be protected under other country's trademark registrations.

5002152 Rev E
3910822948